

ROBAM



使用说明书

User Manual

使用产品前请仔细阅读本使用说明书，并妥善保管。如果说明书丢失，你可以发送邮件至overseas@robam.com，获得电子版说明书。

Before operating this unit, please read the user manual completely and keep it. If the manual is lost, you can send e-mail to overseas@robam.com, request for an electronic manual.

ZTB250-ST10

便携式电蒸箱

Steam Oven



目 录

安全注意事项.....	1
产品简介.....	2
安装说明.....	4
使用说明.....	5
维护和保养.....	14
常见故障及处理方法.....	15
电气原理图.....	15

安全注意事项

为了避免给使用者及其他人员造成危害或者财产损失，特作如下区分及标志。
以下均为有关安全的重要事项，敬请严格遵守，并在充分理解内容的基础上正确使用。

根据危害、损害程度进行的内容区分

 危险	若忽视这一标志，并进行错误操作，极有可能导致人员危险、重伤或引起火灾。
 警告	若忽视这一标志，并进行错误操作，有可能导致人员危险、重伤或引起火灾。
 注意	若忽视这一标志，并进行错误操作，有可能导致人员受伤或造成物品的损害。

注意、禁止内容的图标

 禁止	 禁止明火	 禁止触摸	 禁止拆卸	 严格执行	 需要接地	 当心触电	 小心烫伤
---	---	---	---	---	--	---	---

 **警告** 请严格按照本说明书规定使用，由于本产品使用不当造成的任何财产损失、人身伤害，本公司不承担责任。

 危险	
 严格执行 拔出插座上的插头时，必须手握插头的端部将其拔出，请不要手拿电源线拔插头，否则易发生触电、短路、起火等危险。	 禁止 请不要使用松动或接触不良的电源插座，否则易导致触电、短路、起火等危险。
 严格执行 为避免可能出现的电击，换灯泡前应确定器具已断开电源。	 严格执行 整机远离热源，煤气和酒精等易燃物品。
 小心烫伤 器具在使用期间会发热，注意避免接触器具内的发热单元，以免烫伤和灼伤；工作结束后取出食物时务必戴好耐高温保护手套，以免烫伤。	

 警告	
 严格执行 如果电源软线损坏，为了避免危险，必须由制造商、其维修部或类似部门的专业人员更换。	 需要接地 单独使用10A或以上的插座，请勿与几个电器同时使用同一个电源插座，并确保插座安全有效接地。
 严格执行 若器具出现故障请立即断开电源停止使用，并且不要触摸器具，请专业人员维修。	 严格执行 不得损伤电源线。使用电源线时不得弯曲、拉伸、扭转、打结。不得用重物扣压、夹击电源线。
 严格执行 为防止火警，器具必须保持清洁，风道必须畅通无阻。	 严格执行 工作结束后，打开器具门时会有蒸汽喷出，不要离器具太近，以免蒸汽烫伤。
 严格执行 器具在使用时可触及部分可能会发热，儿童应远离。	 禁止 禁止无人照看的幼儿和残疾人使用此器具，并禁止儿童玩耍器具。

ROBAM老板 | 便携式电蒸箱

 警告	
 禁止 不要使用粗糙洗涤剂或锋利的金属刮刀清洁器具的门玻璃，如果玻璃表面被擦伤，这样做会导致玻璃粉碎。	 禁止 不可将易燃物质（例如烟雾剂）放置器具的里面和下面；使用器具时，不得在其附近喷洒烟雾剂，必须始终有人看管。
 严格执行 器具长期不使用，应切断电源。	 严格执行 如使用不当会导致漏水、漏气现象，请专业维修人员维修。
 严格执行 请勿在手脚潮湿或赤脚的状态下操作器具。	 禁止 不能使用蒸汽清洁器。

 注意	
 严格执行 若器具出现功能不正常时，请拔掉电源插头重新上电。	 严格执行 使用时内部蒸盘等放置必须正确到位。
 严格执行 请使用专用清洗剂清洁器具的腔体及加热盘。且器具不得浸入水中。	 严格执行 当集水槽中水过多时，请采用吸水棉或抹布将水槽中积水吸干。

产品简介

亲爱的用户：

让我们借此机会，对于您购买了老板牌电蒸箱表示衷心的感谢。我们特别建议您在着手使用本产品前，有必要仔细阅读此说明书，并请将其妥善保存，以备今后查阅。

本公司是国内生产吸油烟机、电蒸箱、燃气灶具、消毒柜、电烤箱等家用电器和厨具的专业企业；老板牌电蒸箱采用先进的设计理念，注重整体设计、优化造型；它具有健康、环保、节能等优点。

使用独有的电码防伪标志，保证用户购买正牌产品，维护自身利益。

本产品属于I类器具，使用时必须具有可靠的接地。

本产品不适用于高原地区。

※本说明书中的产品图片仅供参考，产品以实物为准。本公司产品持续改进，因产品改进所引起的内容变更，恕不另行通知。

重要信息

电蒸箱的包装

请以环保的态度处置这些包装材料，以保持一个良好的环境。

请勿让儿童玩耍塑料薄膜、纸箱等包装材料，这可能会产生窒息事故，所以请让包装材料远离儿童。

产品特点

- 玻璃面板，触摸式操控；
- 多种功能烹饪模式使蒸菜任由选择；
- 全不锈钢加热盘，稳定性好、使用寿命长；
- 人性化内腔照明灯设计，随时查看食物状态；
- 过温保护等功能使用更安全。

ROBAM老板 | 便携式电蒸箱

产品结构

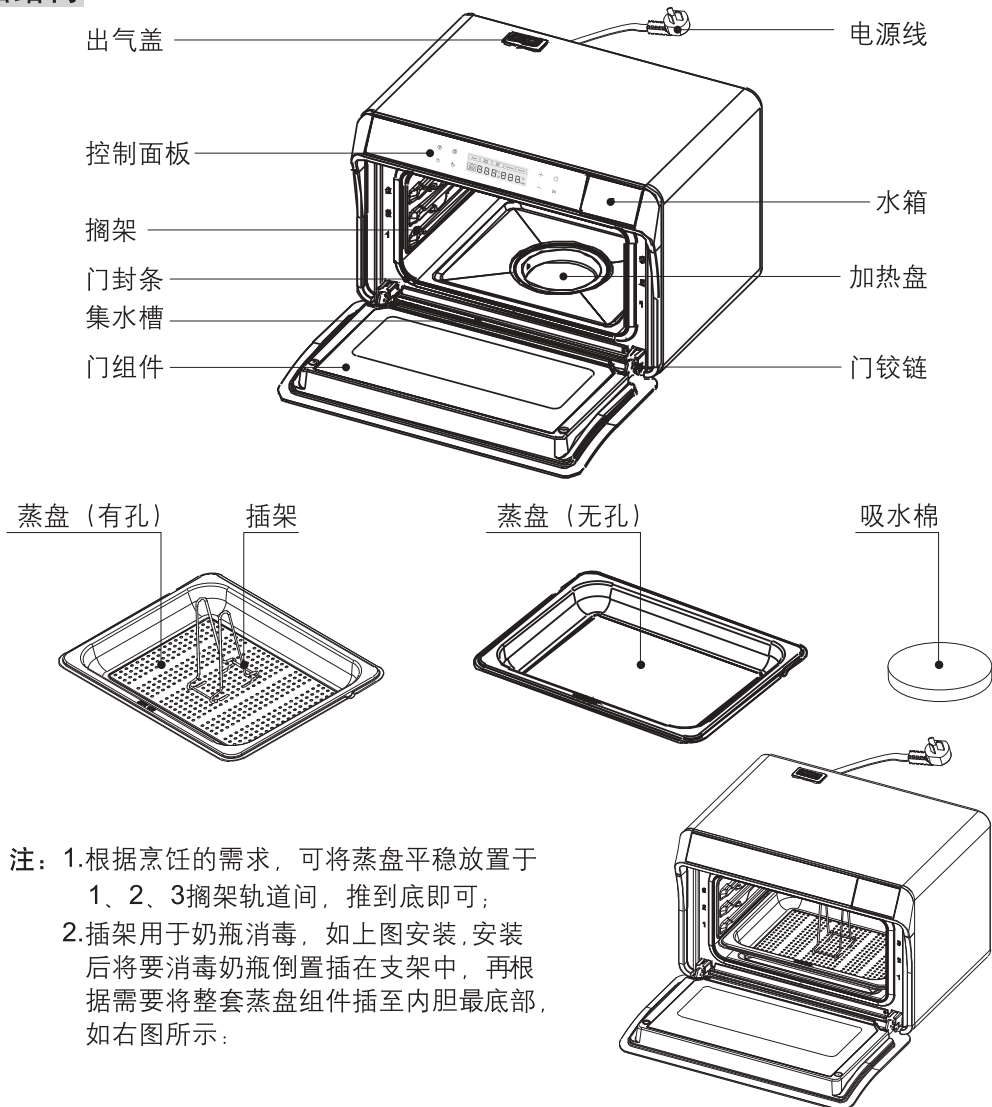

产品技术参数

型号	ZTB250-ST10
额定电压	220-240V~
额定频率	50Hz
额定功率	1800W
容积	25L
工作方式	高温蒸汽
净重	17kg
外形尺寸 宽×高×深(mm)	530×362×390 (高度含出气盖)

附件清单

序号	名称	数量
1	说明书	1份
2	蒸盘（无孔）	1个
3	蒸盘（有孔）	1个
4	吸水棉	1个
5	插架	1个

安装说明

在台面上，按下面安装图示平稳放置电蒸箱，注意不得倾斜放置，具体位置（mm）见下表：

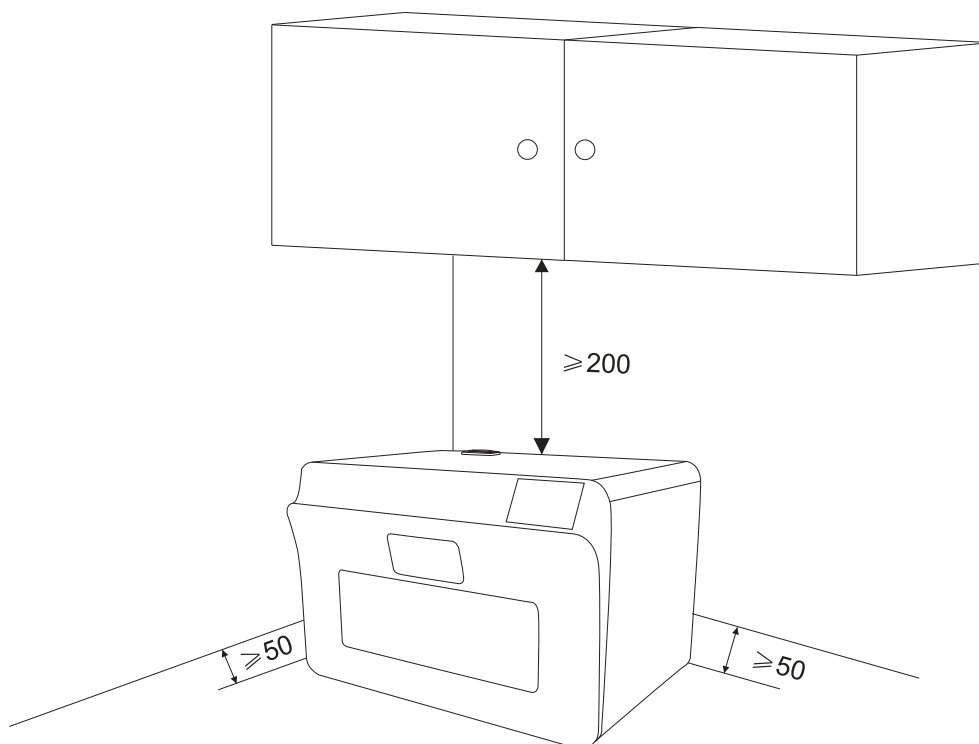

整机放置示意图

安装要求：

- 把电蒸箱内的包装物全部取出。
- 应仔细查看电蒸箱有否损坏。如有损坏，请立刻联络经销商或本公司服务部。
- 此电蒸箱较重，应放置于有足够承托力的水平面上。
- 本电蒸箱应在通风干燥，无腐蚀性气体的环境中使用，远离高温及蒸汽。
- 切勿在电蒸箱顶部放置任何物品，并保持与顶部壁柜距离至少200mm。
- 电蒸箱两旁应与墙壁距离至少50mm，电蒸箱背部应与墙壁至少距离50mm。
- 警告——为了防止触电，必须确保此电蒸箱接地良好。

使用说明

控制面板介绍

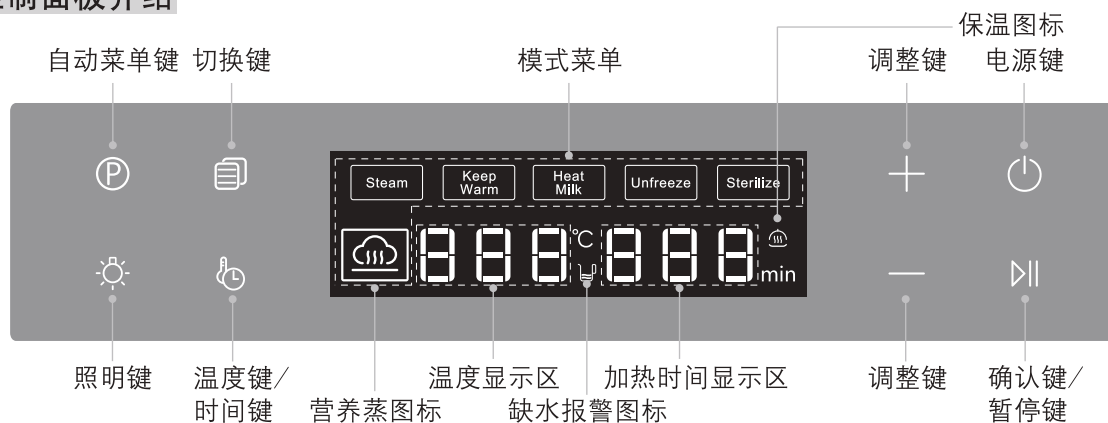

使用前说明

● 水箱加水及安装注意事项:

1. 在开机状态下，按压水箱，弹出，取出水箱(如右图)；
2. 使用前先检查水箱是否干净，如有异味或脏污请及时清洗，切勿用开水清洗；
3. 打开水箱进水口翻盖将水加入水箱中，请加水至最大水位线；
4. 将加完水的水箱推入水箱槽内。

注：● 禁止将热水加入水箱中，以免造成水箱变形及机器损坏。

- 工作状态下，缺水时，“”图标闪烁提示，加水完成，按“”键继续加热。

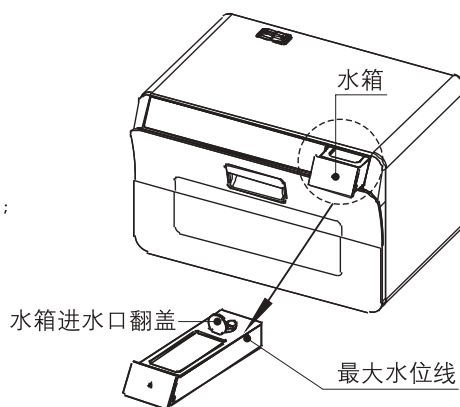



使用方法

1. 通电

接通电源，发出提示音，所有按键灯和显示屏全亮。数秒后“”键闪烁，显示屏和其余灯灭，进入待机状态（如下图）。



注：若数分钟内无任何操作，进入关机状态，所有按键和显示屏灭，“”键半亮（此时除“”键外，按其他任意键，“”键闪烁）。

2. 开机

长按“”键开机，进入模式选择界面（如下图）。



ROBAM老板 | 便携式电蒸箱

3. 选择烹饪模式

按“+”或“-”键选择所需的烹饪模式,被选模式图标闪烁(如选择了“嫩蒸”,如下图)。如需调整温度、时间,则按“⏸”键先后切换到温度、时间显示区,然后按“+”或“-”键进行调节。

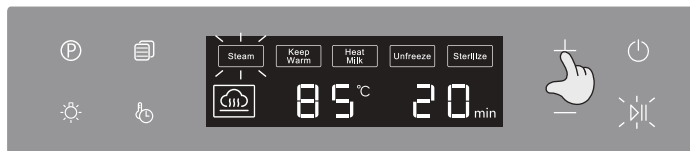

注:●如无需调节温度和时间,模式选择完毕后,可直接按“▶▶”键启动。

- 设定烹饪温度和时间,用户可根据烹饪参考表,也可根据个人口感及烹饪经验调整温度与时间。
- 在温度和时间调节过程中,长按“+”、“-”键为快速递增或递减,按“⏸”键可退出温度、时间调节状态。
- 具有烹饪记忆功能,在未断电的情况下,再次开机工作,可继续使用上次关机前的烹饪模式设置。
- 在调整模式状态下长按“⏸”键可恢复当前模式的默认参数。

4. 确认开始

烹饪模式设定好后,按“▶▶”键启动,显示屏显示实时温度和倒计时时间(如下图),开始烹饪。工作过程中,如需重新调节烹饪模式,则先按“▶▶”键暂停,再按“⏸”键切换至相应模式进行调节。

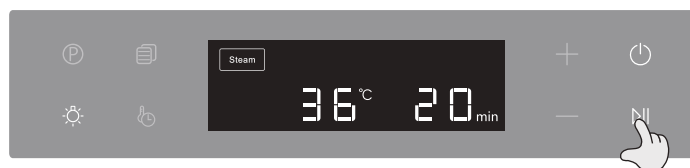

■自动菜单功能

- 1.按“Ⓟ”键进入自动菜单功能。
- 2.按“+”或“-”键可选择所需的自动菜单,对应的显示图标如下:

类别	档位	菜谱	阶段	默认工作时间(min)	时间范围(min)
宝宝菜	P01	清蒸肝糊	6个月	8	6-10
	P02	清蒸鳕鱼	8个月	10	8-12
	P03	鸡肉胡萝卜粥	9个月	60	58-62
	P04	胡萝卜牛肉泥	11个月	40	38-42
	P05	香菇虾仁蛋羹	12个月	11	8-12
妈妈菜	P06	红枣百合蒸南瓜	备孕期	30	28-32
	P07	归芪蒸鸡	备孕期	40	38-42
	P08	剁椒蒸芋仔	孕早期	30	28-32
	P09	蒜蓉蒸明虾	孕早期	3	3-5
	P10	黑芝麻戚风蛋糕	孕早期	50	50-55
	P11	蒜泥蒸丝瓜	孕晚期	10	8-12
	P12	糯米蒸牛肉	孕晚期	80	78-85
	P13	清蒸鲫鱼	产后期	15	13-17

类别	档位	菜谱	阶段	默认工作时间(min)	时间范围(min)
健身菜	P14	蒜蓉蒸鸡胸	训练后1小时	13	13-17
	P15	蒜泥蒸鱼片	训练后1小时	5	5-9
	P16	粉蒸牛肉	训练后1小时	15	13-17
	P17	手撕茄子	通用	10	8-12
	P18	秘汁西兰花	通用	5	5-8
	P19	凉拌秋葵	通用	5	5-8
	P20	海鲜蒸蛋羹	通用	25	23-27

3. 如需调整时间，可按“⌚”键进行调节。

4. 最后按“▶”键启动，开始烹饪。

注：●用户可根据食物的重量或厚度不同，调整烹饪时间。在选择菜单后，时间闪烁，此时可进行调整。

●启动后，如需退出自动菜单模式，需先按“▶”键暂停工作，再按“⏪”键退出。

●默认工作时间为达到设定温度后的工作时长。

菜谱配方及制作方法

(用户可根据自己的烹饪经验及口味自行调整配方)

P01-清蒸肝糊

食材：猪肝125g，鸡蛋半个，清水50g，洋葱20g，香油2g，精盐0.2g，食用油10g。

操作步骤：

1. 将猪肝去掉内部筋膜和血管，切成小片，洗去血水沥干水分，热锅冷油，倒入洋葱和猪肝片一起炒熟，盛出剁成细末；
2. 将炒熟的猪肝末放入碗内，加入鸡蛋液、清水、精盐、香油搅匀，放入电蒸箱，选择P01档进行蒸制，取出即可食用。

P02-清蒸鳕鱼

食材：银鳕鱼200g，姜丝5g。

操作步骤：

1. 将冷冻的银鳕鱼稍微解冻后，洗净表面可能有的鳞片、脏污，装盘；
2. 姜丝洒在银鳕鱼上，放入电蒸箱，选择P02档进行蒸制，取出即可食用。

P03-鸡肉胡萝卜粥

食材：鸡胸肉30g，胡萝卜30g，大米100g，纯净水500g，食用油5g。

操作步骤：

1. 将胡萝卜洗净，切碎；
2. 将鸡胸肉洗净，剔出内部筋膜，切碎；
3. 炒锅内倒入食用油，油温五成热倒入鸡肉泥煸炒变色后，盛出备用；
4. 洗净的大米加水，将胡萝卜、鸡肉泥放入搅拌均匀，选择P03档进行蒸制，取出搅拌均匀即可食用。

P04-胡萝卜牛肉泥

食材：牛里脊100g，胡萝卜50g。

操作步骤：

1. 牛里脊肉洗净切小块，胡萝卜洗净切小块；
2. 牛肉焯水；
3. 焯水之后，牛肉和胡萝卜放入电蒸箱，选择P04档进行蒸制；
4. 蒸好的肉和胡萝卜取出，放入搅拌杯，加入适量的凉开水，搅打成泥，即可食用。

ROBAM老板 | 便携式电蒸箱

P05-香菇虾仁蛋羹

食材：蛋液50g，鲜香菇1个，鲜虾1个，温开水90g，盐0.5g，小葱1根。

操作步骤：

1. 鲜香菇洗净切末，小葱切葱花，鲜虾去壳去虾线备用；
2. 蛋液用手动打蛋器（或筷子）打散，放入盐0.5g搅拌均匀，使盐充分溶化；
3. 加入温开水90g，边打边搅拌，搅匀即可；
4. 将蛋水过筛到炖盅里，用小勺撇去表面气泡，加入处理好的香菇、虾仁；
5. 炖盅顶部盖一个小盘子或保鲜膜，无需预热，选择P05档进行蒸制，取出撒入葱花即可食用。

P06-红枣百合蒸南瓜

食材：南瓜700g，红枣10个，干百合15g，冰糖25g。

操作步骤：

1. 干百合放入清水中发泡至变白，略微清洗备用，若有新鲜百合则无需泡发，小红枣也一起浸泡，浸泡完后去核；
2. 南瓜去瓤去皮，切成大约2cm见方的方块，摆在盘子边缘；
3. 红枣、百合摆在盘子中间，然后均匀撒上冰糖；
4. 放入电蒸箱，无需预热，选择P06档进行蒸制，取出即可食用。

P07-归芪蒸鸡

食材：乌骨鸡1只，黄芪10g，当归5g，料酒10g，白胡椒粉3g，盐3g，葱10g，生姜10g。

操作步骤：

1. 乌骨鸡清洗干净，然后切块；
2. 当归、黄芪、生姜、葱洗净后，生姜切片，葱切长段；
3. 将乌骨鸡块、当归、黄芪、姜片、葱段和料酒一起装盘放入电蒸箱，选择P07档进行蒸制；
4. 取出，撒入白胡椒粉和盐即可。

P08-剁椒蒸芋仔

食材：小芋仔150g，剁椒30g。

操作步骤：

1. 小芋仔洗净、去皮，对半切开，整齐码入盘中；
2. 剁椒30g，均匀撒在芋仔表面；
3. 将芋仔放入电蒸箱，选择P08档进行蒸制，取出即可食用。

P09-蒜蓉蒸明虾

食材：明虾200g，蒜5g，姜5g，生抽10g，糖2g，料酒5g。

操作步骤：

1. 虾洗净，挑去虾线，在碗内摆放均匀，蒜拍破与姜一起剁成蓉；
2. 在另一碗内将生抽、糖和蒜蓉、姜末混匀，用勺子淋在每只虾身上；
3. 将虾放入电蒸箱，选择P09档进行蒸制，取出即可食用。

P10-黑芝麻戚风蛋糕

食材：鸡蛋5个，黑芝麻粉30g，低筋面粉60g，牛奶50g，色拉油50g，白糖65g，柠檬汁几滴。

操作步骤：

1. 蛋黄加20g白糖，搅打均匀；
2. 加入色拉油和牛奶，搅拌均匀；
3. 加入黑芝麻粉（炒熟黑芝麻磨成粉），搅拌均匀后筛入低筋面粉，搅拌均匀；
4. 蛋白加入几滴柠檬汁，打至鱼眼泡状后，分3次加入45g白糖，打发至偏干性发泡，即提起有尖尖的小角不往下掉；
5. 1/3蛋白加入蛋黄糊，搅拌均匀，全部倒入蛋白糊，快速翻拌均匀，成蛋糕糊；
6. 倒入8寸活底模具，轻轻磕几下去除气泡；
7. 将模具放入电蒸箱中，选择P10档进行蒸制；
8. 蒸好后取出，轻震两下散出热气，倒扣，放凉至完全凉透；
9. 用手轻按蛋糕表面使之与模具脱离，活底往上轻轻顶出蛋糕体，轻拨边缘与活底脱离，即可食用。

P11-蒜泥蒸丝瓜

食材：丝瓜300g，蒜瓣10g，盐1g，麻油3g。

操作步骤：

1. 大蒜去皮剁成蒜泥，丝瓜切片放大盘里，加盐1g，蒜泥10g；
2. 放入电蒸箱中，选择P11档进行蒸制，取出后淋上麻油3g即可食用。

P12-糯米蒸牛肉

食材：牛肉100g，糯米200g，蚝油15g，老抽10g，盐2g，糖4g，胡椒粉1g。

操作步骤：

1. 糯米泡10h以上，牛肉切丁泡水1h后沥干水分；
2. 牛肉中加蚝油7.5g、老抽5g、盐1g、糖2g、胡椒粉0.5g拌匀，腌3min；
3. 糯米加蚝油7.5g、老抽5g、盐1g、糖2g、胡椒粉0.5g拌匀；
4. 把腌好的牛肉和糯米拌匀，放入电蒸箱，选择P12档进行蒸制，取出即可食用。

P13-清蒸鲫鱼

食材：鲫鱼1条（约500g），猪肉丝20g，冬菇丝20g，盐3g，姜丝15g，葱2根，鲜酱油6g，蒸鱼豉油3g。

操作步骤：

1. 将鲫鱼宰好，除内脏，洗净沥干水分，装盘；
2. 用盐3g涂抹于鱼肚中，生姜丝部分塞入鲫鱼鱼肚内；
3. 用葱两三条放在碟底，葱上放鲫鱼；
4. 猪肉丝、冬菇丝、姜丝、鲜酱油拌一起搅匀，放在鱼身上；
5. 将鲫鱼放入电蒸箱内，选择P13档进行蒸制；
6. 取出，将生葱丝放于鱼上，加蒸鱼豉油3g，淋上热油，即可食用。

ROBAM老板 | 便携式电蒸箱

P14-蒜蓉蒸鸡胸

食材：鸡胸脯肉200g，蒜10g，剁辣椒5g，黑胡椒粉0.5g，盐0.5g，小葱5g。

操作步骤：

1. 蒜剁成碎，小葱切葱花；
2. 鸡胸脯肉片2片，用刀拍打；
3. 倒入盐0.5g、黑胡椒粉0.5g、蒜末10g、剁辣椒5g，将鸡胸肉腌制15min；
4. 把腌好的鸡胸脯肉放入盘子，选择P14档进行蒸制；
5. 取出撒上葱花。

P15-蒜泥蒸鱼片

食材：黑鱼1200g（一条），蒜20g，小葱5g，剁椒10g，盐0.5g，食用油10g。

操作步骤：

1. 黑鱼洗净，去头去尾去骨，把鱼肉片成片，摆成盘；
2. 蒜剁碎，小葱切碎；
3. 锅中放油，下入蒜末炒金黄，加入剁椒、盐翻炒均匀，倒入铺好的鱼片上；
4. 选择P15档进行蒸制。
5. 取出，撒上小葱碎即可食用。

P16-粉蒸牛肉

食材：牛里脊肉200g，大米40g，盐3g，料酒5g，生抽3g，姜5g，葱10g。

操作步骤：

1. 牛肉切片放入碗中，姜切片，葱切段，大米用搅拌机碾成粉；
2. 切好的牛肉片装盘，用姜片5g，葱段10g，料酒5g，盐3g，生抽3g抓匀，腌制10min；
3. 腌好的牛肉片，挑出姜片和葱段，加入大米粉搅拌均匀，放入盘子中；
4. 选择P16档进行蒸制，取出即可食用。

P17-手撕茄子

食材：茄子300g，红椒10g，青椒10g，小米椒10g，蒜20g，生抽20g，香油5g。

操作步骤：

1. 茄子洗净装盘，蒜切末，小米椒切圈，红椒、青椒切末；
2. 把蒜末20g、生抽20g、香油5g、小米椒10g、青椒末10g、红椒末10g，放到碗里调好汁备用；
3. 选择P17档进行蒸制；
4. 取出蒸好的茄子放凉，把凉好的茄子用手撕成条，装入盘子，把调好的汁淋到撕好的茄子上，摆盘即可食用。

P18-秘汁西兰花

食材：西兰花200g，蒜5g，泰式甜辣酱30g，食用油10g，盐0.5g，清水50g。

操作步骤：

1. 西兰花洗净切块装盘，蒜切末；
2. 选择P18档进行蒸制；
3. 锅中放油，下入蒜末炒香，加入泰式甜辣酱，加入清水50g熬制成汁；
4. 拿出蒸好的西兰花去水，把熬制的汁淋到菜上，即可食用。

P19-凉拌秋葵

食材：秋葵300g，大蒜半个，小红椒1个，食用油15g，生抽20g，米醋30g，香油5g。

操作步骤：

1. 秋葵洗净，去蒂，装盘；
2. 选择P19档进行蒸制；
3. 拿出蒸好的秋葵去水，上面淋入生抽20g、米醋30g、香油5g；
4. 锅中放油，放入蒜末、小红椒末炒香，把熬制的蒜蓉汁淋到菜上即可。

P20-海鲜蒸蛋羹

食材：鸡蛋2个，虾仁50g，鱿鱼50g，蟹足棒50g，鲜贝肉20g，盐2g，蚝油10g、姜5g、蒜5g、小葱5g，食用油10g，水800g(温水300g、清水500g)。

操作步骤：

1. 鸡蛋打入碗中，充分打散，虾仁洗净去虾线，鱿鱼洗净，切花刀，蟹足棒切块，鲜贝肉温水泡10min；
2. 姜切片，蒜切片，小葱切碎；
3. 准备温水300g，放入盐，倒入打散的鸡蛋液中搅拌均匀，用勺子撇去浮沫，盖上保鲜膜；
4. 选择P20档进行蒸制；
5. 锅中放入清水500g，水开下入虾仁、鱿鱼、蟹足棒、鲜贝肉1min捞出；
6. 锅中放油10g，下入姜片、蒜片炒香，加入烫好的虾仁、鱿鱼、蟹足棒、鲜贝肉炒匀，加入蚝油10g调味，把炒好的海鲜倒入蒸好的鸡蛋羹上，最后撒上小葱碎，即可食用。

■照明功能

按“”键开机时，自动开启照明灯；在烹饪过程中，按“”键可开启、关闭照明功能；在照明状态下，数分钟后自动熄灭。

■关机

1. 工作过程中，长按“”键，直接停止加热，进入关机状态。
2. 在烹饪暂停状态下（无任何操作的状态时），数分钟后进入关机状态。
3. 工作结束后，蜂鸣器鸣叫提示，进入待机状态，数分钟后无操作进入关机状态。

ROBAM老板 | 便携式电蒸箱

食品烹饪参考表

菜单模式	食材	烹饪时间(min)	温度(°C)	备注
 营养蒸	五花肉	30	100	约重400克, 切成块状
	排骨	40	100	约重500克, 剁成块状
	肉饼	15	100	约重350克, 剁成肉末
	粉蒸肉	25	100	约重400克, 切成块状
	鲈鱼	15	100	约重500克, 鱼背剖刀深浅均匀
	鲫鱼	15	100	约重500克, 鱼背剖刀深浅均匀
	草鱼	8	100	约重1000克, 切成块状
	米饭	30	100	米约300克, 米水比例1:1.2
	猪蹄	120	100	约重500克, 切成块状
	手工馒头	12	100	约重150克/个, 共6个, 分两盘同时蒸, 蒸完焖10min
	手工包子	15	100	45-50克/个
	手工蒸饺	10	100	20-30克/个
	手工发糕	35	100	8寸圆模
	玉米	20	100	2根
	紫薯	35	100	约重500克, 切成块状
	山药	25	100	约重400克, 切成块状
	胡萝卜	15	100	约重200克, 切成块状
	南瓜	30	100	约重500克, 切成块状
	鸡	50	100	约重1300克
	鸭	80	100	约重1200克(半只)
嫩蒸	水蒸蛋	25	95	2个, 将鸡蛋打散, 蛋水比例1:3
	鸡蛋	12	95	整个
	娃娃菜	16	95	约重300克
	腊肠	13	90	约重100克,切片
	大闸蟹	17	95	6只(约重500克),蒸时用线绳捆好
	大黄鱼	18	85	约重350克, 鱼背剖刀深浅均匀
	小黄鱼	13	90	4条鱼, 约重500克
	豆腐鱼	10	90	5条鱼, 约重200克
	舌鳎鱼	10	95	1条鱼, 约重135克
	鸡腿	30	85	琵琶腿, 约重250克
	明虾	8	95	约重250克
	河虾	8	90	约重300克
	蛤蜊	8	95	约重250克
	肉圆	12	95	8-10个, 约重350克
	鸡蛋米糕	45	80	每份35克左右, 大小直径5cm、高3cm

注: 1. 以上表格中食物烹饪温度、时间只做参考, 食物在烹饪过程中, 用户可根据个人口感及烹饪经验调节温度、时间、菜单模式。

辅助功能温馨提示

1. 温奶模式（默认温度50℃）

食材	器皿	容量(ml)	季节/时间(min)			备注
			春/秋	夏	冬	
母乳	玻璃奶瓶	50	10	9	11	适用解冻后冷藏取出， 起始温度8±2℃
		100	17	16	18	
		150	18	17	20	
		200	20	18	22	
	塑料奶瓶	50	10	9	11	
		100	12	11	13	
		150	15	14	17	
		200	19	17	21	
奶粉 (配方奶)	玻璃奶瓶	50	9	8	10	适用起始温度 20±5℃
		100	12	8	18	
		150	15	11	21	
		200	18	16	24	
	塑料奶瓶	50	9	8	10	
		100	10	8	15	
		150	13	11	17	
		200	16	13	19	
牛奶 (鲜牛乳)	玻璃杯 陶瓷杯	100	15	14	16	适用冷藏，起始温度 8±2℃
		150	16	15	17	
		200	18	16	19	

2. 解冻模式

食材	温度(℃)	烹饪时间(min)	重量 (g)	备注
排骨	50	15-18	400-500	食材采购后，先分成小份，整成平铺形状，再放入冰箱冷冻，这样操作解冻时间会缩短。肉末和排骨可以借助乐扣盒整形。
	50	30-35	800-1000	
五花肉	50	14-18	400-500	
	50	20-25	800-1000	
鸡肉	50	14-18	400-500	
	50	25-30	800-1000	
肉末	50	23-28	400-500	

ROBAM老板 | 便携式电蒸箱

模式菜单

菜单	默认工作温度(°C)	默认工作时间(min)	温度范围(°C)	时间范围(min)
 营养蒸	100	15	35-100	01-180
嫩蒸	85	20	80-95	01-180
保温	60	60	60-70	01-180
温奶	50	30	45-50	01-180
解冻	50	20	40-60	01-180
杀菌	100	30	100	01-180

维护和保养

重要提示：清洗电蒸箱前，必须先切断电蒸箱的电源。

在正常使用后建议清洗或维护

- 每次使用后，待机器冷却之后用抹布将内胆清洗干净并擦干或者打开门让其自然风干。
- 每次使用后，请取出水箱将水倒掉以免时间过久会产生异味。
- 使用后必须及时把集水槽中的积水清理干净，防止水溢出到橱柜上。

在正常使用后建议每周定期清洗或维护，清洗时整机不得浸入水中

- **清洗内胆：**难去除的污渍可用尼龙刷或中性清洁剂清洗，不可用钢丝球擦洗，以免造成表面不可修复的损伤。清洗后用抹布擦干，保持腔内干燥（注：清洗时不要使用具有腐蚀性和具有研磨性的清洁剂清洗。）；
- **清洗门面：**牢固的污垢可用中性清洁剂清洗，不可用钢丝球擦洗，以免划伤表面，清洗后用抹布擦干；
- **清洗加热盘：**请将除垢剂或白醋放入加热盘内，使用杀菌功能加热10-20分钟后关闭功能，待冷却后清除污水。

门封条安装方法

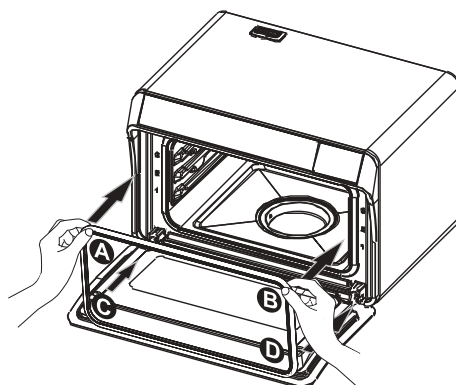

双手捏到门封条上边左右两个A、B半圆角处，对准前板上边的半圆角沟槽，用力压入；再将下边左右两个C、D半圆角处，对准前板下边的半圆角沟槽，用力压入；再分别将四条边完全压入到沟槽内，压入后确保平整、不起皱，无缝隙。

常见故障及处理方法

下表所列为一故障现象，请按所列指示进行确认和处理，如仍处理不了或不能确认故障原因时，请与当地经销商或售后服务中心联系。为了您的安全着想，我们特别提醒：请勿自行拆卸修理。

故障现象	原因	处理方法
不能工作	是否停电、电源插头是否插好	待通电后使用
显示屏不亮	电源不通或者电脑板故障	检查电源情况或请专业人员维修
照明灯不亮	电源不通或灯泡故障	检查电源情况或更换灯泡
工作时有漏气漏水现象	门没关紧、门封条未装到位或门封条损坏	检查门关闭情况、重新安装门封条或请联系专业维修人员
显示屏显示“E3”	水箱缺水、水箱未推到位或流量计故障	添加水或联系专业维修人员
水箱无法弹出	反弹器故障	请联系专业维修人员
加热错误 E3	加热盘的温度传感器安装不良	请联系专业维修人员
显示屏显示 E5	蒸箱内温度传感器故障	请联系专业维修人员
显示屏显示 E6	通讯故障（显示板连接线异常）	请联系专业维修人员

警告：在使用前，请将水箱推压到位；在清洗过程中，请勿将异物堵塞进水口。

电气原理图

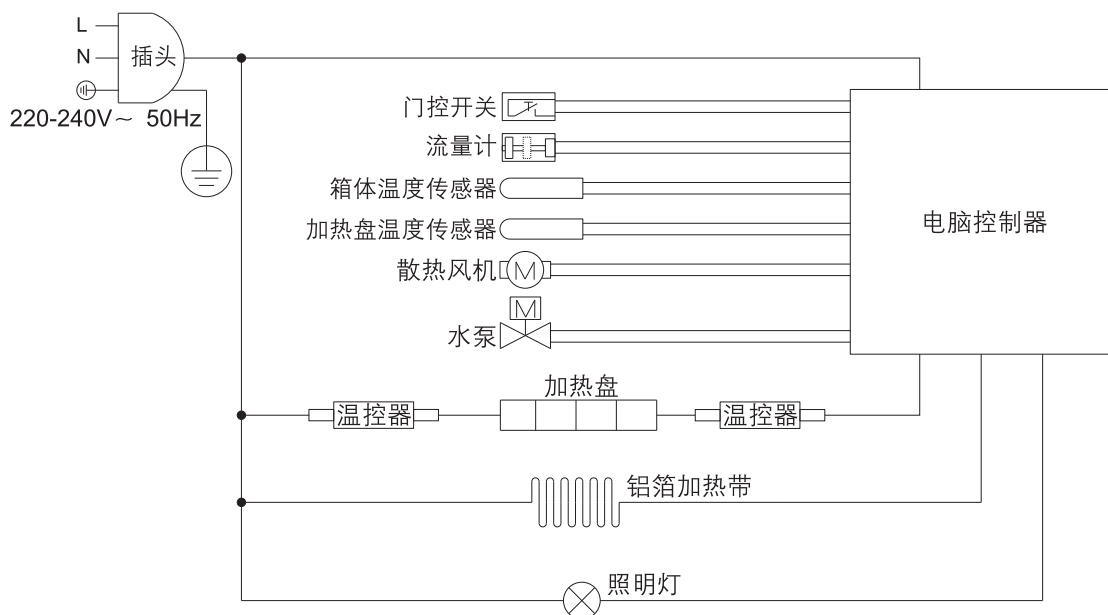

Content



Safety Precautions	1
Product Introduction	4
Installation Instructions	6
Operation Instructions	7
Maintenance	18
Common Faults and Treatment Methods	19
Electrical Schematic Diagram.....	19

Safety Precautions









In order to avoid any harm or property damage to the users and other persons, following distinctions and signs are specially given.

All these are the important notices concerned with safety, so please abide by these notices strictly. And, please use this product correctly on the premise that all the contents herein are understood fully.

Distinctions on contents made in accordance with extent of harm and damage

 Danger	Personal risk, serious injury or a fire may be very likely caused if this sign is neglected and the product is operated improperly.
 Warning	Personal risk, serious injury or a fire may be caused if this sign is neglected and the product is operated improperly.
 Notice	Personal injury or damage to objects may be caused if this sign is neglected and the product is operated improperly.

Signs of the behaviors that shall be paid attention to or that shall be prohibited





 Prohibited	 No open flames	 No touch	 No remove	 Abide by strictly	 To be grounded	 Electric shock danger	 Hot surface
--	--	--	---	---	---	---	---

















Warning Please use this product strictly in accordance with contents of this Operation Manual. Our company is not reliable for any property loss or personal injury caused by improper using of this product.









Danger

 Abide by strictly	When disconnecting the plug, hold the end of the plug by hand. Do not pull the Supply Cord to disconnect the plug. Otherwise it may cause electric shock, short circuit, fire or other risks.
 Prohibited	Do not use the power socket with loose or bad contact problem. Otherwise it may cause electric shock, short circuit, fire or other risks.
 Abide by strictly	In order to avoid any potential electric shock risk, make sure the appliance is disconnected from the power supply before replacing the bulb.
 Abide by strictly	Keep the whole unit away from the heat source, gas, alcohol or other flammable materials.
 Hot surface	The appliance is hot during the operation. So not touch the heating unit in the steam oven to avoid burns. When cooking is done, oven gloves must be used to take out the food to protect from being burnt.





 Warning

 Abide by strictly	If the supply cord is damaged, it must be replaced by the manufacturer, its service agent or similarly qualified persons in order to avoid a hazard.
 To be grounded	Separately use the socket of 10A or above. Do not use the same socket together with other electric appliance. Make sure the socket is securely and effectively grounded.
 Abide by strictly	In case of any malfunction occurred, immediately disconnect the power supply. Do not touch the appliance and contact the professional person for repair.
 Abide by strictly	Do not damage the Supply Cord. Make sure the Supply Cord is not bent, stretched, twisted or knotted. Do not use any weight to press on or pinch the Supply Cord.
 Abide by strictly	In order project against fire, appliance must be kept in clean condition and the air passage must be kept unobstructed.
 Abide by strictly	When cooking is done, open the appliance door carefully. Hot steam will escape upon opening the door. Do not stay too close to the appliance to project against burnt by the steam.
 Abide by strictly	Accessible parts may become hot during use. Young children should be kept away.
 Prohibited	It is forbidden for unattended children and disabled people to use this appliance, and it is also forbidden for children to play with it.
 Prohibited	Do not use the rough detergent or sharp metal blade to clean the door glass of the appliance. If the glass surface is scratched, it may cause glass broken.
 Prohibited	Do not place the flammable substance (such as the smoke agent) inside or under the steam oven. When the appliance is in operation, do not spray smoke agent near the oven. Do not use appliance unattended.
 Abide by strictly	Disconnect the power supply when the appliance is not in use for long time.
 Abide by strictly	Improper use may result in water or gas leak. Contact the qualified service personnel for service.
 Prohibited	Children should be supervised to ensure that they do not play with the appliance.

 **Warning**

-  The steam cleaner is not to be used for cleaning.
Abide by strictly
-  Steam cleaners cannot be used.
Prohibited
-  This appliance is not intended for use by persons (including children) with reduced physical, sensory or mental capabilities, or lack of experience and knowledge, unless they have been given supervision or instruction concerning use of the appliance by a person responsible for their safety.
Prohibited
-  This appliance just for household use only.
Prohibited
-  Warning: Avoid spillage on the connector.
Abide by strictly
-  Warning: There will be a potential injury from misuse.
Abide by strictly
-  Warning: The heating element surface is subject to residual heat after use.
Abide by strictly

 **Notice**

-  In the event of any malfunction, unplug the appliance from outlet.
Abide by strictly
-  During use, the steaming tray and other items should be correctly placed in the oven.
Abide by strictly
-  Use the special cleaner to clean the chamber and Hotplate of the steam oven. And the appliance must not be immersed.
Abide by strictly
-  When the water in the water collecting tank is too excessive, adopt the absorbent cotton or cloth to absorb the water.
Abide by strictly

Product Introduction

Dear users:

We would like to extend our sincere appreciation to you for your purchase of ROBAM steam oven. We hereby recommended you to read this instruction manual carefully before installing or using the appliance. Save these instructions properly for future reference.

ROBAM is a nationwide specialized enterprise in manufacturing exhaust hood, steam oven, gas cooker, disinfection cabinet, electric oven and other household appliance & kitchen wares. ROBAM steam oven adopts the advanced design concept and attaches importance to the overall design as well as shape optimization. It is distinct with a variety of characteristics such as healthy, environmental & energy sufficiency, etc.

This appliance is accounted as class I utensil. It must be grounded when in use.

The appliance is not applicable for plateau region.

※ The pictures of the products in this manual are for reference only, and the products are subject to the actual objects. The company's products continue to improve, and changes in content due to product improvement will be made without prior notice.

Important Information

Steam Oven Package

Please dispose these packaging materials in an environment-friendly way, in order to keep a good environment. Be sure not to allow children to play with the packaging materials (e.g. plastic film and carton box, etc.), otherwise it would lead to suffocation accident. So, please keep children away from the packaging materials.

Product Characteristics

- Glass panel with one-touch manipulation;
- Multi-function cooking mode provides more diverse steaming choices;
- Completely stainless steel Hotplate with more steady performance and longer service life;
- Humanized chamber lighting design for checking food status from time to time;
- Electromagnetic lock, over-temperature protection and other functions make the use much safer.

Product structure

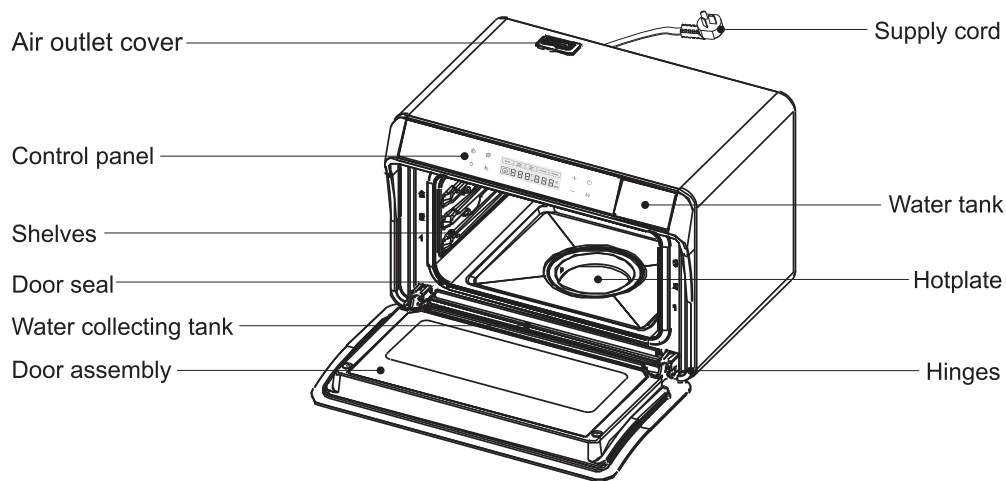

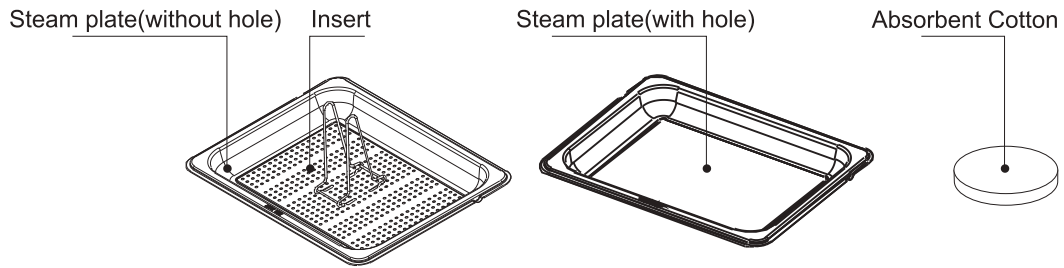

Product structure

Note: 1. According to the cooking requirements, the steaming tray can be stably placed on 1, 2, 3 shelf track, push to the end;
 2. Insert is used for bottle disinfection. It is installed as shown in the above figure. After installation, the bottle to be sterilized is inserted into the bracket upside down, and then the whole set of steaming tray assembly is inserted into the bottom of the inner container as required, as shown in the right figure:

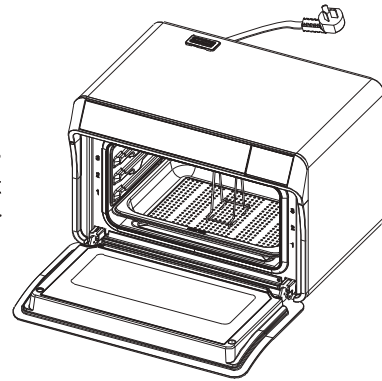

Technical Parameters of the Product

Model	ZTB250-ST10
Rated Voltage	220-240V~
Rated Frequency	50Hz
Rated Power	1800W
Capacity	25L
Working Mode	High temperature steaming
Net Weight	17kg
Dimensions W×H×D(mm)	530×362×390 (height with Air outlet cover)

Accessories

S/N	Name	Quantity
1	User Manual	1 Pcs
2	Steam Plate(without hole)	1 Pcs
3	Steam Plate(with hole)	1 Pcs
4	Absorbent Cotton	1 Pcs
5	Insert	1 Pcs

Installation instructions

On the table top, place the Steam Oven steadily as shown in the installation diagram below, and be careful not to place it obliquely. See the following table for the specific position (mm):

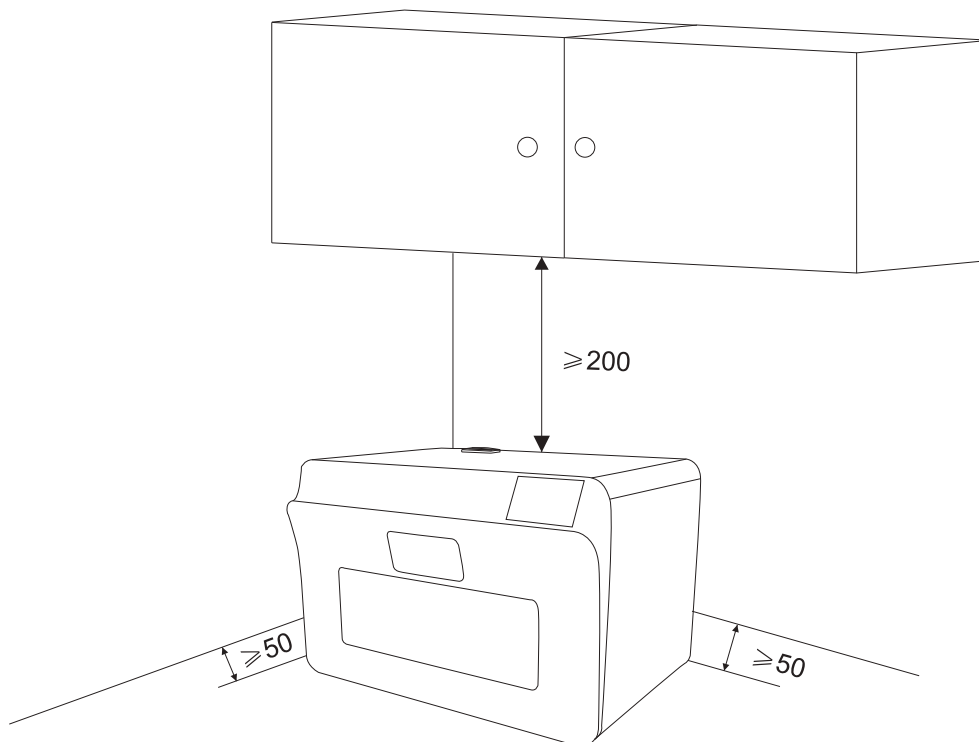

Schematic diagram of whole machine placement

Installation requirements:

- Take out all the packages in the Steam Oven.
- Should carefully check whether the Steam Oven is damaged. If there is any damage, please contact the distributor or our service department immediately.
- This Steam Oven is heavy and should be placed on a horizontal plane with sufficient support.
- This Steam Oven should be used in a ventilated and dry environment without corrosive gas, away from high temperature and steam.
- Do not place anything on the top of the Steam Oven and keep a distance of at least 200mm from the top wall cabinet.
- Both sides of the Steam Oven should be at least 50mm away from the wall, and the back of the Steam Oven should be at least 50mm away from the wall.
- Warning-In order to prevent electric shock, it is necessary to ensure that the Steam Oven is well grounded.

Operation Instructions

Introduction to Control Panel

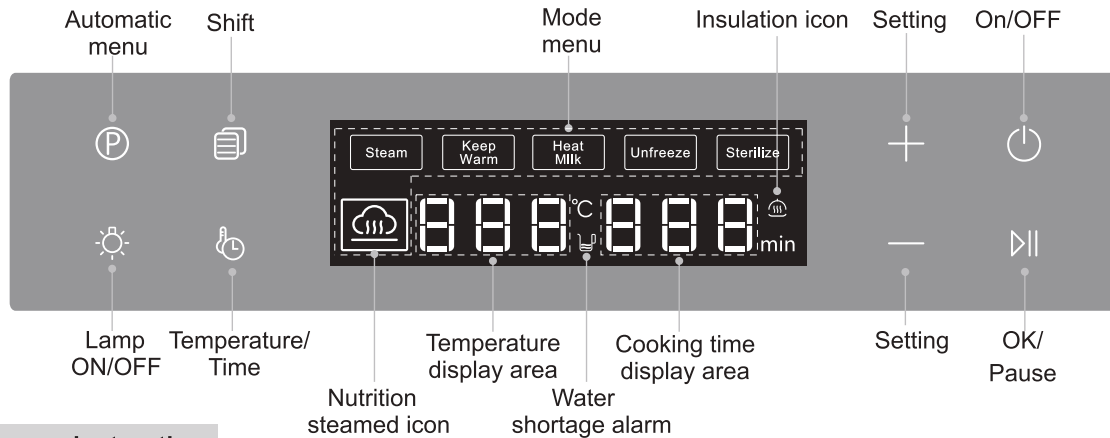



Pre-use instructions

● Water tank filling and installation precautions:

1. In the startup state, press the water tank, pop it up, and take out the water tank (as shown in the right figure);
2. Before use, check whether the water tank is clean. If there is any peculiar smell or dirt, please clean it in time. Do not clean it with boiled water;
3. Open the water tank inlet flap to add water to the water tank, please add water to the maximum water level;
4. Push the filled water tank into the tank.

Note: ● It is forbidden to add hot water into the water tank to avoid deformation of the water tank and damage to the machine.

- In the working state, when there is water shortage. “” icon flashing prompt, add water to complete, press “” Key to continue heating.

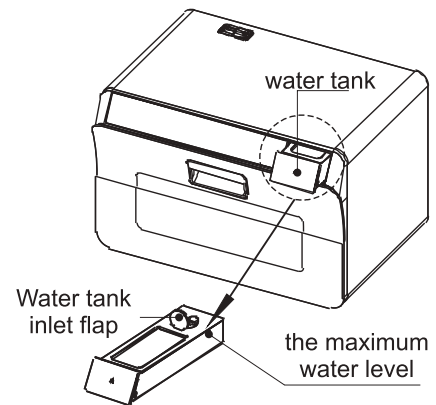



Use method

1. Power on

Turn on the power supply and sound a prompt tone. All key lights and display screen will be on. After a few seconds “” Key flashing, display screen and the rest of the lights go out, enter to stay Machine status (as shown in the following figure).



Note: If there is no operation within a few minutes, enter the shutdown state, and all keys and display screen will be off. “” Key half bright (except at this time “” Press any other key except the key. “” Key flashing).

2. Starting up

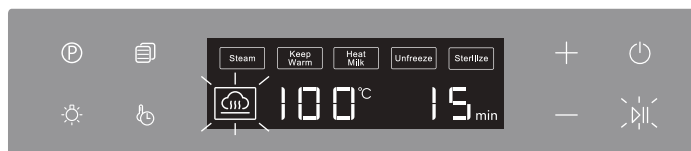

Press long “” key to start up, enter the mode selection interface (as shown in the figure below).



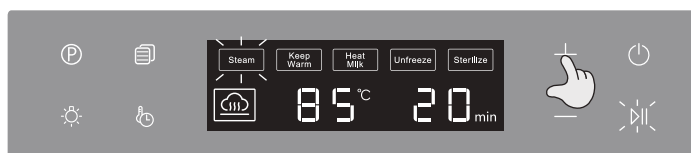

3. Select cooking mode

Press the “+” or “-” key to select the desired cooking mode, and the icon of the selected mode will flash (for example, “tender steaming” is selected, as shown in the following figure). To adjust the temperature and time, press “” key switches to the temperature and time display area successively, and then presses “+” or “-” key to adjust.



- Note:
- If there is no need to adjust the temperature and time, press directly after the mode is selected. “” key to start.
 - Set the cooking temperature and time. Users can adjust the temperature and time according to the cooking reference table or personal taste and cooking experience.
 - In the process of temperature and time adjustment, press the “+” and “-” keys for rapid increase or decrease, and press the “” key to exit the temperature and time adjustment state.
 - It has a cooking memory function. When the power is not cut off, it will start up again and can continue to use the cooking mode setting before the last shutdown.
 - Press the “” key long in the adjustment mode state to restore the default parameters of the current mode.

4. Confirm start

After the cooking mode is set, press “” key starts, and the display screen displays the real-time temperature and countdown time (as shown in the figure below) to start cooking. During work, if you need to readjust the cooking mode, press “” key pause, then press “” key to switch to the corresponding mode for adjustment.

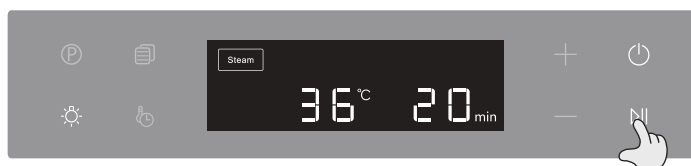

Automatic menu function

1. Press the “Ⓟ” key to enter the automatic menu function.
2. Press the “+” or “-” key to select the required automatic menu, and the corresponding display icons are as follows:

Category	Stall	Menu	Stage	Default working time (min)	Time range (min)
Dishes for Babies	P01	Steam Minced Liver	6 months	8	6-10
	P02	Steam Codfish	8 months	10	8-12
	P03	Chicken Porridge	9 months	60	58-62
	P04	Carrot Meat Puree	11 months	40	38-42
	P05	Shrimp Egg Custard	12 months	11	8-12
Dishes for Moms	P06	Steam Pumpkin	late pregnancy	30	28-32
	P07	Steam Chicken	late pregnancy	40	38-42
	P08	Steam Taro	Early pregnancy	30	28-32
	P09	Steam Prawns	Early pregnancy	3	3-5
	P10	Chiffon Cake	Early pregnancy	50	50-55
	P11	Steam Towel Gourd	late pregnancy	10	8-12
	P12	Steam Meat with Glutinous Rice	late pregnancy	80	78-85
	P13	Steam Crucian Carp	puerperium	15	13-17
Dishes for Fitness	P14	Steam Chicken Breast	One hour after training	13	13-17
	P15	Steam Fish Fillets	One hour after training	5	5-9
	P16	Steam Meat with Rice Powder	One hour after training	15	13-17
	P17	Steam Sliced Eggplant	currency	10	8-12
	P18	Steam Broccoli	currency	5	5-8
	P19	Okra with Sauces	currency	5	5-8
	P20	Steam Egg with Seafood	currency	25	23-27

3. To adjust the time, press “⌚” Key to adjust.

4. Finally, press “ ▷|| ” Key to start, start cooking.

Note:● Users can adjust the cooking time according to the weight or thickness of food. After selecting the menu, the time flashes and can be adjusted at this time.

- After startup, if you want to exit the automatic menu mode, you need to press the “ ▷|| ” key to pause the work and then press the “ ≡ ” key to exit.
- The default working time is the working time after reaching the set temperature.

Recipe formula and preparation method thereof

(Users can adjust the formula according to their cooking experience and taste)

P01-Steam Minced Liver

Ingredients: liver 125g, egg half, water 50g, onion 20g, sesame oil 2g, refined salt 0.2g, edible oil 10g.

Operating steps:

- 1.Removing internal fascia and blood vessels from liver, cutting into small pieces, washing off blood, draining water, heating to cool oil, adding onion and liver slices, parching, cutting into fine powder;
- 2.Put the fried liver powder into a bowl, add egg liquid, clear water, refined salt and sesame oil, stir well, put into a Steam Oven, select P01 for steaming, and take out for eating.

P02-Steam Codfish

Ingredients: codfish 200g, shredded ginger 5g.

Operating steps:

- 1.Defrost the frozen codfish slightly, clean the scales and dirt on the surface, and put them on a plate;
- 2.Sprinkle shredded ginger on codfish, put into the Steam Oven, select P02 to steam, take out and serve.

P03-Chicken Porridge

Ingredients: chicken breast 30g, carrot 30g, rice 100g, purified water 500g, edible oil 5g.

Operating steps:

- 1.Wash carrots and chop them up;
- 2.Cleaning chicken breast, removing internal fascia, and cutting;
- 3.Pour edible oil into the frying pan, add chicken puree when the oil temperature is 50% hot, stir-fry until it changes color, and then pour it out for later use;
- 4.Wash rice and add water. Add carrot and chicken puree and stir well. Select P03 to steam. Take out and stir well, serve.

P04-Carrot Meat Puree

Ingredients: meat fillet 100g, carrot 50g.

Operating steps:

- 1.Wash Meat tenderloin and cut it into small pieces, wash carrot and cut it into small pieces;
- 2.Blanching meat;
- 3.After blanching, Meat and carrots are put into a Steam Oven, and P04 is selected for steaming;
- 4.Take out the steamed meat and carrots, put them into a mixing cup, add a proper amount of cold boiled water, stir them into mud, and serve.

P05-Shrimp Egg Custard

Ingredients: egg liquid 50g, fresh mushroom 1pcs, fresh shrimp 1pcs, warm boiled water 90g, salt 0.5g, spring onion 1pcs.

Operating steps:

- 1.Wash fresh mushrooms and cut them into powder, cut shallots and chopped scallions, shell fresh shrimps and remove shrimp lines for later use;
- 2.Use a manual egg beater (or chopsticks) to break up the egg liquid, add 0.5g of salt and stir evenly to fully dissolve the salt;
- 3.Add 90g of warm boiled water, beat while stirring, and stir well;
- 4.Sift the egg water into the stewing cup, skim off the surface bubbles with a small spoon, and add the processed mushrooms and shrimps;
- 5.Cover the top of the stewing cup with a small plate or plastic wrap, do not need preheating, select P05 for steaming, take out and sprinkle chopped green onion to eat.

P06-Steam Pumpkin

Ingredients: pumpkin 700g, red dates 10pcs, dried lily 15g, crystal sugar 25g.

Operating steps:

- 1.Dried lilies are put into clear water to be foamed until white, and are slightly washed for later use. If there are fresh lilies, the hair does not need to be soaked, and the small red dates are soaked together, and the cores are removed after soaking;
- 2.Remove the pulp and peel the pumpkin, cut it into squares about 2cm square, and place it on the edge of the plate;
- 3.Place red dates and lilies in the middle of the plate, then sprinkle crystal sugar evenly;
- 4.Put it into a Steam Oven without preheating. Select P06 for steaming and take.

P07-Steam Chicken

Ingredients: black-bone chicken 1pcs, astragalus root 10g, angelica 5g, cooking wine 10g, white pepper powder 3g, salt 3g, onion 10g, ginger 10g.

Operating steps:

- 1.Clean the black-bone chicken and cut it into pieces;
- 2.Cleaning radix Angelicae sinensis, radix astragali, Rhizoma Zingiberis recens, and Herba alii fistulosi, slicing Rhizoma Zingiberis recens, and cutting Herba alii fistulosi into long sections;
- 3.Put the black-bone chicken pieces, angelica, astragalus root, ginger slices, scallion segments and cooking wine into a Steam Oven, and select P07 for steaming;
- 4.Remove and sprinkle with white pepper and salt.

P08-Steam Taro

Ingredients: small taro 150g, chopped pepper 30g.

Operating steps:

- 1.Wash and peel the young taro, cut it in half, and put it into the dish neatly;
- 2.30g chopped pepper, evenly sprinkled on the surface of taro seed;
- 3.Put the taro seed into the Steam Oven, select P08 for steaming, and take it out to eat.

P09-Steam Prawns

Ingredients: prawn 200g, garlic 5g, ginger 5g, raw pork 10g, sugar 2g, cooking wine 5g.

Operating steps:

1. Wash the prawns, pick out the prawns and place them evenly in the bowl. Chop the garlic and ginger into paste;
2. In another bowl, mix the raw smoke, sugar, garlic and ginger, and pour onto each prawn with a spoon;
3. Put the prawns into the Steam Oven, select P09 for steaming, and take out to eat.

P10-Chiffon Cake

Ingredients: eggs 5pcs, black sesame powder 30g, low gluten flour 60g, milk 50g, salad oil 50g, white sugar 65g, lemon juice a few.

Operating steps:

1. Add 20g white sugar to egg yolk and beat it evenly;
2. Add salad oil and milk and stir well;
3. Adding black sesame powder (parched black sesame is ground into powder), stirring uniformly, sieving low-gluten flour, and stirring uniformly;
4. Add a few drops of lemon juice to the egg whites, beat until the fish's eyes are bubble-shaped, add 45g of white sugar three times, and beat until the egg whites are slightly dry and foamy, i.e. lift the sharp corners and do not fall off;
5. 1/3 albumen is added with yolk paste, cut and mixed evenly, all the albumen paste is poured in, and quickly turned and mixed evenly to form cake paste;
6. Pour into an 8-inch living bottom mold and gently knock it down to remove bubbles;
7. Put the mold into a Steam Oven, and select P10 for steaming;
8. After steaming, take it out, gently shake it twice to release the heat, turn it upside down, and let it cool until it is completely cool;
9. Use your hand to gently press the cake surface to separate it from the mold, gently push the movable bottom upwards out of the cake body, and gently push the edge to separate from the movable bottom, then you can eat.

P11-Steam Towel Gourd

Ingredients: loofah 300g, garlic 10g, salt 1g, sesame oil 3g.

Operating steps:

1. Peel garlic and chop it into mashed garlic. Slice loofah and put it in a large plate. Add 1g salt and 10 g mashed garlic;
2. Put it into a Steam Oven, select P11 for steaming, take it out and pour 3g sesame oil on it.

P12-Steam Meat with Glutinous Rice

Ingredients: meat 100g, glutinous rice 200g, oyster sauce 15g, old soy sauce 10g, salt 2g, sugar 4g, pepper 1g.

Operating steps:

1. Soak glutinous rice for more than 10h, cut meat into cubes, soak in water for 1h, and drain off water;
2. Add 7.5g oyster sauce, 5g soy sauce, 1g salt, 2g sugar and 0.5g pepper to meat, mix well and marinate for 3min;
3. Mix glutinous rice with oyster sauce 7.5g, soy sauce 5g, salt 1g, sugar 2g and pepper powder 0.5g evenly;
4. Mix pickled meat and glutinous rice well, put them into a Steam Oven, select P12 for steaming, and take them out to eat.

P13-Steam Crucian Carp

Ingredients: crucian carp 1pcs(about 500g), pork shreds 20g, mushroom shreds 20g, salt 3g, ginger shreds 15g, scallions 2pcs, fresh soy sauce 6g, steamed fish soy sauce 3g.

Operating steps:

1. Slaughter crucian carp, eviscerate, wash, drain and plate;
2. 3g of salt is applied to the fish maw, and ginger shreds are partially inserted into the crucian fish maw;
3. Place two or three scallions on the bottom of the dish and crucian carp on the scallions;
4. Stir pork shreds, mushroom shreds, ginger shreds and fresh soy sauce together and put them on the fish body;
5. Put crucian carp into a Steam Oven and select P13 file for steaming;
6. Take it out, put the shredded green onion on the fish, add 3g steamed fish soy sauce, and pour hot oil on it. You can eat it.

P14-Steam Chicken Breast

Ingredients: chicken breast meat 200g, garlic 10g, chopped chili 5g, black pepper 0.5g, salt 0.5g, shallot 5g.

Operating steps:

1. Chop garlic into pieces, cut shallot into chopped scallion;
2. 2 pieces of chicken breast meat, beat with a knife;
3. Pour in 0.5g salt, 0.5g black pepper powder, 10g garlic powder and 5g chopped chili, and marinate chicken breast for 15min;
4. Put the pickled chicken breast meat on a plate and select P14 for steaming;
5. Remove and sprinkle chopped green onion.

P15-Steam Fish Fillets

Ingredients: black fish 1200g (1pcs), garlic 20g, scallion 5g, chopped pepper 10g, salt 0.5g, edible oil 10g.

Operating steps:

1. Wash black fish, remove head, tail and bone, slice the fish into pieces and arrange them into plates;
2. Chop garlic and shallots;
3. Put oil in the pan, add garlic powder and fry until golden brown, add chopped pepper and salt, stir fry evenly, and pour into the paved fish fillet;
4. Select P15 for steaming;
5. Take out, sprinkle chopped scallion and serve.

P16-Steam Meat with Rice Powder

Ingredients: meat tenderloin 200g, rice 40g, salt 3g, cooking wine 5g, raw pork 3g, ginger 5g, onion 10g.

Operating steps:

- 1.Slice meat into bowls, slice ginger, slice scallions, and grind rice into powder with a blender;
- 2.The cut meat slices are put into a plate, and are evenly grasped with 5g of ginger slices, 10g of scallion segments, 5g of cooking wine, 3g of salt and 3g of raw pork, and pickled for 10min;
- 3.Pickled meat slices, picking out ginger slices and scallion segments, adding rice flour, stirring evenly, and putting into a plate;
- 4.Select P16 file for steaming, take out and serve.

P17-Steam Sliced Eggplant

Ingredients: eggplant 300g, red pepper 10g, green pepper 10g, millet pepper 10g, garlic 20g, raw soy sauce 20g, sesame oil 5g.

Operating steps:

- 1.Wash eggplant and put it on a plate, cut garlic into powder, cut millet pepper into rings, cut red pepper and green pepper into powder;
- 2.20g of garlic powder, 20g of raw extract, 5g of sesame oil, 10g of millet pepper, 10g of green pepper powder and 10g of red pepper powder are put into a bowl to be mixed with juice for later use;
- 3.Select P17 for steaming;
- 4.Take out the steamed eggplant and let it cool. Tear the cooled eggplant into strips by hand and put them on a plate. Pour the mixed juice onto the torn eggplant and put it on a plate for eating.

P18-Steam Broccoli

Ingredients: broccoli 200g, garlic 5g, Thai sweet and spicy sauce 30g, edible oil 10g, salt 0.5g, water 50g.

Operating steps:

- 1.Wash broccoli, cut into pieces, put them on a plate, and cut garlic into pieces;
- 2.Select P18 for steaming;
- 3.Add oil into the pan, add garlic powder and stir-fry until fragrant, add Thai sweet and spicy sauce, add 50g of clear water and boil to obtain juice;
- 4.Take out the steamed broccoli, remove the water, and pour the boiled juice onto the vegetables to eat.

P19-Okra with Sauces

Ingredients: okra 300g, garlic half, red pepper 1pcs, edible oil 15g, raw soy sauce 20g, rice vinegar 30g, sesame oil 5g.

Operating steps:

- 1.Washing okra, removing pedicles, and loading into plates;
- 2.Select P19 for steaming;
- 3.Take out steamed okra and remove water. Pour 20g of raw extract, 30g of rice vinegar and 5g of sesame oil onto it;
- 4.Add oil to the pan, add garlic powder and red pepper powder, stir-fry until fragrant, and pour the boiled garlic juice onto the vegetables.

P20-Steam Egg with Seafood

Ingredients: eggs 2pcs, shrimps 50g, squid 50g, crab sticks 50g, fresh shellfish meat 20g, salt 2g, oyster sauce 10g, ginger 5g, garlic 5g, shallot 5g, edible oil 10g, water 800g (300g warm water and 500g clear water).

Operating steps:

1. Beat the eggs into a bowl and break them up thoroughly. Wash the shrimps and remove the shrimps, wash the squid, cut the flowers with a knife, cut the crab legs into pieces, and soak the fresh shellfish in warm water for 10min;
2. Slice ginger, garlic and shallot;
3. Prepare 300g of warm water, add salt, pour into the beaten egg liquid, stir well, skim off floating foam with a spoon, and cover with plastic wrap;
4. Select P20 for steaming;
5. 500g of clear water is put into the pot, shrimp, squid, crab sticks and fresh shellfish are put into the water for 1min and fished out;
6. Put 10g of oil into the pan, add ginger slices and garlic slices, stir-fry until fragrant, add fried shrimps, squid, crab sticks and fresh shellfish, stir-fry well, and add oyster sauce 10g seasonings, pour the fried seafood into the steamed egg custard, and finally sprinkle chopped scallion to serve.

Lighting Function

Press the “☺” key to turn on the lights automatically; During cooking, press the “☺” key can turn on and off the lighting function; In the lighting state, it will turn off automatically after a few minutes.

Power OFF

1. During the working process, press the “☺” key for a long time to stop heating directly and enter the shutdown state.
2. In the cooking pause state (when there is no operation), it will enter the shutdown state after several minutes.
3. After the work is finished, the buzzer will sound to prompt and enter the standby state. After several minutes, no operation will enter the shutdown state.

Food Cooking Reference Table

Menu mode	Ingredients	Temperature (°C)	Cooking time (min)	Remarks
 Nutritional steaming	Marbled meat	100	30	Weighing about 400g, cut into pieces
	Spareribs	100	40	Weighing about 500g, chop into pieces
	Meat pie	100	15	Weighing about 350g, chop into minced meat
	Steam meat	100	25	Weighing about 400g, cut into pieces
	Perch	100	15	Weighing about 500g, the fish's back is even in depth
	Crucian	100	15	Weighing about 500g, the fish's back is even in depth
	Grass carp	100	8	Weighing about 1000g, cut into pieces
	Rice	100	30	Rice about 300g, rice to water ratio 1:1.2
	Crabeens	100	120	Weighing about 500g, cut into pieces
	Handmade steamed bread	100	12	Weighing about 150g/piece, a total of 6 pieces, are steamed simultaneously in two plates and braised for 10min

Menu mode	Ingredients	Temperature (°C)	Cooking time (min)	Remarks
 Nutritional steaming	Handmade steamed buns	100	15	45-50g/piece
	Steam dumplings by hand	100	10	20-30g/piece
	Hand-made sponge cake	100	35	8-inch round mould
	Corn	100	20	Two pcs
	Purple sweet potato	100	35	Weighing about 500g, cut into pieces
	Yam	100	25	Weighing about 400g, cut into pieces
	Carrot	100	15	Weighing about 200g, cut into pieces
	Pumpkin	100	30	Weighing about 500g, cut into pieces
	Chicken	100	50	Weighing about 1300 g
	Duck	100	80	About 1200 grams (half)
Steam tender	Steam egg custard	95	25	Two eggs, break up the eggs, egg-water ratio 1:3
	Egg	95	12	The whole
	Baby cabbage	95	16	Weighing about 300g
	Sausage	90	13	Weighing about 100g, slice
	Hairy crabs	95	17	6 pieces (about 500g in weight) are bundled with string during steaming
	Large yellow croaker	85	18	Weighing about 350g, the fish's back is even in depth
	Little yellow croaker	90	13	Four fish, weighing about 500g
	Bean curd fish	90	10	Five fish, weighing about 200g
	Tongue sole	95	10	One fish, weighing about 135g
	Drumstick	85	30	Drumsticks, weighing about 250g
	Prawn	95	8	Weighing about 250g
	Shrimp	90	8	Weighing about 300g
	Clam	95	8	Weighing about 250g
	Meatballs	95	12	8-10, weighing 350g
Egg rice cake	80	45	Each serving is about 35g, with a diameter of 5cm and a height of 3cm	

Note: 1. The food cooking temperature and time in the above table are for reference only. During the cooking process, the user can adjust the temperature, time and menu mode according to personal taste and cooking experience.

Warm Tips for Auxiliary Functions

1. Warm milk mode (default temperature 50°C)

Ingredients	vessel	Capacity (ml)	Season/time (min)			Remarks
			Spring/ Autumn	Summer	Winter	
Breast milk	Glass bottle	50	10	9	11	Applicable to be frozen and taken out after thawing, starting initial temperature of 8±2°C
		100	17	16	18	
		150	18	17	20	
		200	20	18	22	
	Plastic bottle	50	10	9	11	
		100	12	11	13	
		150	15	14	17	
		200	19	17	21	
Milk powder (formula milk)	Glass bottle	50	9	8	10	Applicable starting temperature of 20±5°C
		100	12	8	18	
		150	15	11	21	
		200	18	16	24	
	Plastic bottle	50	9	8	10	
		100	10	8	15	
		150	13	11	17	
		200	16	13	19	
Milk (fresh milk)	Glass ceramic cup	100	15	14	16	Applicable cold storage, starting temperature of 8±2°C
		150	16	15	17	
		200	18	16	19	

2. Thawing mode

Ingredients	Temperature (°C)	Cooking time (min)	Weight (g)	Remarks
Spareribs	50	15-18	400-500	After the food is purchased, it is first divided into small portions, and then put into a refrigerator for freezing. The thawing time of this operation will be shortened. Minced meat and ribs can be reshaped with the aid of a buckle box.
	50	30-35	800-1000	
Marbled meat	50	14-18	400-500	
	50	20-25	800-1000	
Chicken	50	14-18	400-500	
	50	25-30	800-1000	
Minced meat	50	23-28	400-500	

Mode menu

Menu	Default operating temperature (°C)	Default working time (min)	Temperature range (°C)	Time range (min)
 Nutritional steaming	100	15	35-100	01-180
Steamed tender	85	20	80-95	01-180
Heat preservation	60	60	60-70	01-180
Warm milk	50	30	45-50	01-180
Thaw	50	20	40-60	01-180
Sterilization	100	30	100	01-180

Maintenance

Important Note: Before cleaning the electric steam box, the power supply of the electric steam box must be cut off. Cleaning or maintenance is recommended after normal use.

- After each use, after the machine cools down, clean the inner container with cloth and dry it or open the door to allow it to dry naturally.
- After each use, please take out the water tank and pour out the water so as not to generate peculiar smell over time.
- After use, the accumulated water in the water collecting tank must be cleaned in time to prevent the water from overflowing onto the cabinet.

After normal use, it is recommended to clean or maintain the machine regularly every week. During cleaning, the whole machine shall not be immersed in water.

- Cleaning the inner container: difficult to remove stains can be cleaned with nylon brush or neutral detergent, and cannot be scrubbed with steel wire balls, so as not to cause irreparable damage to the surface. After cleaning, wipe dry with cloth and keep the cavity dry (Note: Do not use corrosive and abrasive cleaning agents to clean the appliance.).
- Cleaning the facade: the firm dirt can be cleaned with neutral detergent, and cannot be scrubbed with steel wire balls to avoid scratching the surface. After cleaning, wipe it dry with cloth.
- Cleaning the heating plate: please put the detergent or white vinegar into the heating plate, use the sterilization function to heat for 10-20 minutes, then turn off the function, and remove the sewage after cooling.

Installation method of door seal

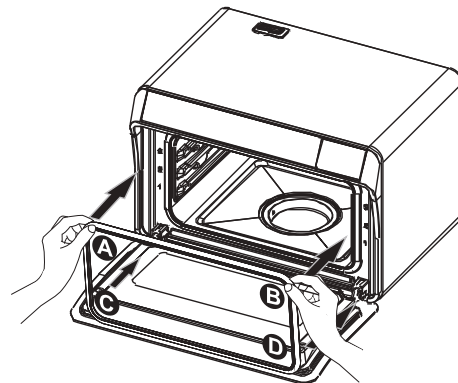

Pinch both hands to the left and right A and B semi-fillets on the upper edge of the door seal, align with the semi-filleted groove on the upper edge of the front plate, and press in firmly; Then, align the left and right C and D semi-fillets at the lower edge with the semi-filleted groove at the lower edge of the front plate, and press in firmly; Then press the four edges into the groove completely, and ensure that they are flat, wrinkle-free and seamless after press-in.

Common Faults and Treatment Methods

The following table lists common faults. Please confirm and handle them according to the listed instructions. If the fault cannot be handled or the cause can not be confirmed, please contact the local dealer or after-sales service center. For the sake of your safety, we specially remind you not to disassemble and repair it yourself.

Problem	Possible Causes	What to Do
Steam oven will not start to work	Check if power is cut or the unit is correctly plugged in	Use after the power is connected
Display panel will not come up	Power is not connected or the PCB malfunctions	Check the power connection or contact the qualified personnel for repair
Light will not come on	Power is not connected or bulb failure	Check the power connection or replace the bulb
Leak gas or water during working	Water tank needs more water. Tank was not pushed in place or the water level check switch fails	Check if the door is closed. Reinstall door seal or contact the qualified personnel for repair
Display problem $\text{E} \exists$	Door is not closed. Door seal is not installed in place or damaged	Add more water or contact the qualified personnel for repair
Water tank is unable to pop out	Push rod motor failure	Contact the qualified personnel for repair
Incorrect heating $\text{E} \exists$	Heating plate or connection wire failure	Contact the qualified personnel for repair
Display problem $\text{E} \text{S}$	Temperature sensor inside the oven malfunction	Contact the qualified personnel for repair
Display problem $\text{E} \text{E}$	Communication failure (Connection wire of the display panel fails)	Contact the qualified personnel for repair

Warning: Please push the water tank into place before use. During the cleaning process, do not block the water inlet with foreign matters.

Electrical Schematic Diagram

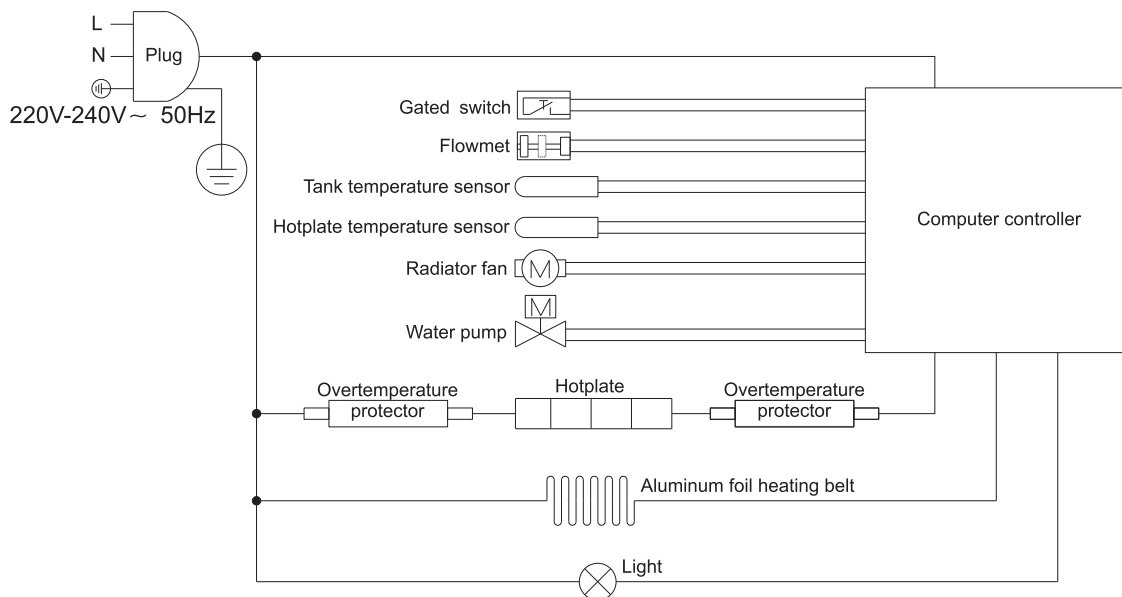

版次: A/0

出版日期: 2019年09月20日

Edition: A/0

Publication date: September 20, 2019



ROBAM