

**ROBAM**

Edition: A/1

Publication date: November 15, 2025

版次: A/1

出版日期: 2025年11月15日

**ROBAM**



**User Manual**  
**使用说明书**  
**ZKQC-60-CQ768**

Combi Steam Oven  
蒸烤炸一体机

If the manual is lost, you can send e-mail to [overseas@robam.com](mailto:overseas@robam.com), request for an electronic manual.  
如果说明书丢失, 您可以发送电子邮件至 [overseas@robam.com](mailto:overseas@robam.com), 申请电子版说明书。

# Contents

Safety Precautions ..... 1  
 Product Introduction ..... 3  
 Installation Instructions ..... 5  
 Instructions for Use ..... 7  
 Common Faults and Solutions ..... 20  
 Maintenance and Care ..... 21  
 Electrical Schematic Diagram ..... 24

## Safety Precautions

All of the following instructions are important safety instructions. Please strictly observe them and use them correctly after fully understanding them. We will not be liable for any property loss or personal injury whatsoever arising as a result of improper operation of this product.

- ◆ Before disconnecting plug from the socket, you should grip the end of the plug. Be sure not to disconnect the plug with power wire in your hand, otherwise such dangers as electric shock, short out and fire may be caused.
- ◆ Be sure not to use a power socket which is loose or contacted poorly, otherwise such dangers as electric shock, short out and fire may be caused.
- ◆ During use the appliance becomes hot. Care should be taken to avoid touching heating elements inside the oven. When taking out foods after using, make sure to wear the high-temperature resistant protective gloves properly in order to avoid burns.
- ◆ The complete appliance shall be kept far away from heat sources and inflammables (e.g. gas and alcohol).
- ◆ If the supply cord is damaged, it must be replaced by the manufacturer, its service agent or similarly qualified persons in order to avoid a hazard.
- ◆ Use 15A socket alone, and be sure not to connect several appliances to the same power socket at the same time, and make sure that the socket is grounded safely and effectively.
- ◆ If the appliance functions improper, make sure to disconnect it from the power and stop using immediately. And, be sure not to touch the appliance and that it is repaired by a professional.
- ◆ Make sure the power cord is not damaged. When using the power cord, make sure that the cord is not bent, stretched, twisted or knotted. And, Be sure not to press or attack the power cord with weight.
- ◆ In order to avoid fire alarm, appliance must be kept in clean condition and the air passage must be kept unobstructed.
- ◆ This appliance should be connected to a circuit which incorporates an isolating switch providing full disconnection from the power supply .

- ◆ After the steam mode is finished, there will be steam coming out when you open the appliance door. Do not open the appliance in the direction of the door to avoid steam burns.
- ◆ This appliance is not intended for use by persons (including children)with reduced physical,sensory or mental capabilities, or lack of experience and knowledge, unless they have been given supervision or instruction concerning use of the appliance by a person responsible for their safety.
- ◆ Children should be supervised to ensure that they do not play with the appliance.
- ◆ **WARNING: Accessible parts may become hot during use. Young children should be kept away.**
- ◆ **WARNING: Ensure that the appliance is switched off before replacing the lamp to avoid the possibility of electric shock.**
- ◆ **WARNING: Do not use harsh abrasive cleaners or sharp metal scrapers to clean the oven door glass/the glass of hinged lids of the hob(as appropriate),since they can scratch the surface,which may result in shattering of the glass.**
- ◆ **WARNING: If the surface is cracked, switch off the appliance to avoid the possibility of electric shock.**
- ◆ Do not place the flammable substance (such as the smoke agent) inside or under the steam oven. When the appliance is in operation, do not spray smoke agent near the oven. Do not use appliance unattended.
- ◆ Disconnect the power supply when the appliance is not in use for long time.
- ◆ Improper use may result in water or gas leak. Contact the qualified service personnel for service.
- ◆ Be sure not to operate the appliance when any of your hand or foot is wet or your feet are bare.
- ◆ Make sure to disconnect the electric oven from power before removing the fan guard. After cleaning, reset the guard properly to the original position in accordance with the Operation Manual.
- ◆ Turn off the appliance as soon as it is ready for use, otherwise residual fat can start a fire.
- ◆ You should cut off the power before cleaning of the appliance and use a neutral detergent to clean it. Moreover, make sure to clean it with a soft piece of cloth, in order to prevent its surface from being scratched.
- ◆ If the appliance functions abnormal, please disconnect the power plug and power it on again.
- ◆ When using the fryer grill, baking tray, steam plate, make sure place in the right position.
- ◆ The appliance cannot be used as an indoor heater.
- ◆ Steam cleaner is not to be used.
- ◆ When the water in the drip tray is too excessive, adopt the absorbent cotton or

cloth to absorb the water.

- ◆ This appliance just for household use only.
- ◆ The appliance must not be installed behind a decorative door in order to avoid overheating.
- ◆ When cooking with Grill Mode, grease can catch fire if overheated. Do not try to extinguish burning grease with water; turn appliance off or unplug it, and keep the appliance door closed to stop the flame from spreading. Never leave the appliance unattended when cooking food with fat.
- ◆ When cooking with Grill Mode, grilling food for too long can cause it dry out and have the risk of catching fire. Do not exceed the recommended cooking time.

## Product Introduction

### Dear Users

Thank you for choosing Robam product. We recommend that you read this manual carefully before installing and using this product and keep it for future reference.

The company is a professional enterprise producing range hood, combi steam oven, gas stove, disinfection cabinet, electric oven and other household appliances and kitchenware. Robam combi steam oven adopts advanced design concept, focusing on overall design and model optimization.

※ All pictures of the product in the Manual are for reference only. The real products shall prevail. Our products are constantly improved. The manual will be subject to change without prior notice.

### Important Information

Packaging of Combi Steam Oven

Please dispose of these packaging materials in an environmentally friendly way to maintain a good environment.

Do not allow children to play with packaging materials such as plastic films and paper boxes, as this may cause suffocation accidents. Therefore, please keep the packaging materials away from children.

### List of Attachments

S/N	Description	Quantity	S/N	Description	Quantity
1	User manual	1	7	Steam plate (with hole)	1
2	ST3.5*30 screw	2	8	Toasting fork assembly	1
3	Fried grill	1	9	Rotating baking rack	1
4	Baking tray	1			
5	Shelf	2			
6	Descaling agent	1			

### Technical Parameters of the Product

Model	ZKQC-60-CQ768
Rated Voltage	220V-240V~
Rated Frequency	50Hz-60Hz
Rated Power	3300W
Overall Volume	73L
Net Weight	43kg
Dimensions (mm) width × height × depth	595 × 595 × 545
Energy Efficiency Test Mode	Convection
Usable Volume	60L
Useable internal dimension (mm) width × height × depth	427 × 377 × 368

### Product Structure

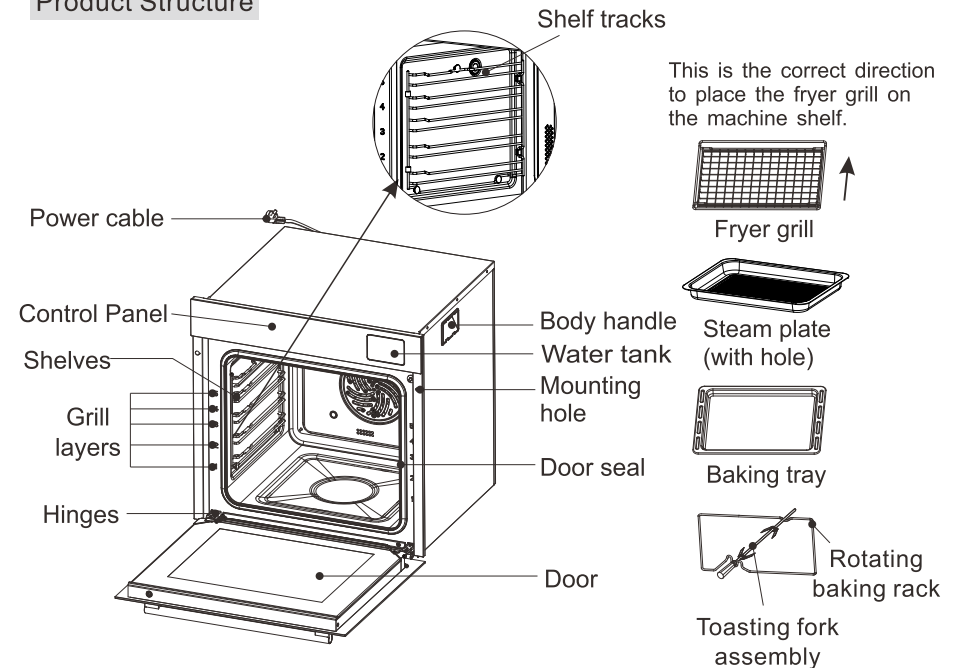

**Note:** Depending on the cooking needs, you can place the fryer grill, baking tray and steam plate(with hole) smoothly between the shelf tracks and push them to the bottom.

## Installation Instructions

In the setting position of the cabinet, set the square hole according to the installation diagram below, insert the electric oven into the square hole smoothly, and pay attention not to tilt it. The specific opening size (mm) is shown in the table below:

S/N	Description	W	H	D
1	Fully embedded opening size	600	600	565
2	Semi-embedded opening size	560	590	550

### Installation requirements:

- The cabinet plane or counter top where the utensils are placed must be level.
- Try to circulate the air around the utensils in the cabinet, and it is recommended that the splint and fixing plate be moisture-proof, waterproof, corrosion-proof, and non-flammable.
- Use the two mounting screws to fix the body to the cabinet through the fixing holes on the left and right door frames.

### Power requirements

- For permanent installation. The circuit must be fitted with appropriate cutting and protection devices, and the plugs and sockets connecting to the power supply should be of the same type and comply with the relevant local requirements.
- The power cord must be easily accessible. Ensure that the appliance can be disconnected at any time after installation. Use the 15A socket alone. Do not use the same power socket with several appliances and make sure that the socket is securely and effectively grounded.
- If there are other electrical appliances around, please make sure that the installation distance is greater than 100mm.

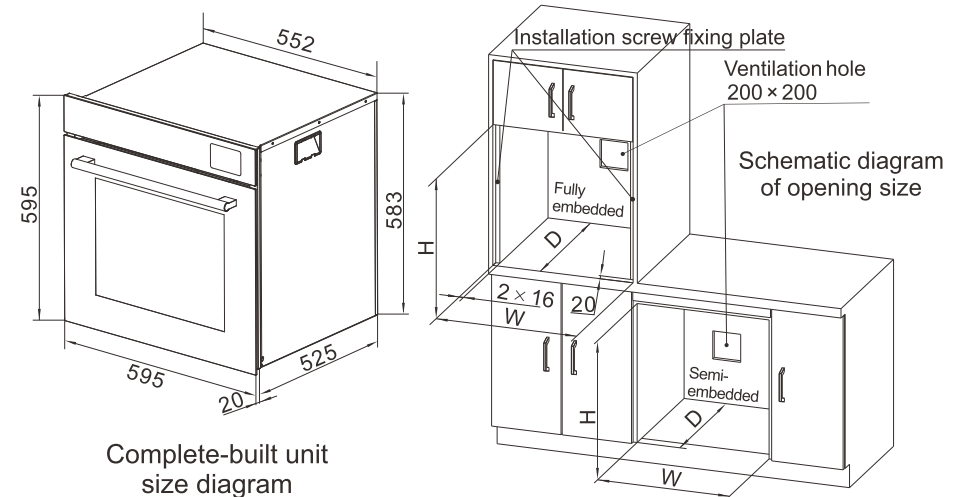

Complete-built unit size diagram

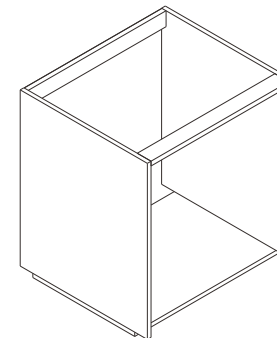

Baseplate side plate  
Front  
Side view

Front view

### Note:

- When the product installation location is the cabinet, in order to ensure that the product door body and the left and right cabinet doors form an overall consistent visual effect, it is recommended to use the cabinet structure diagram shown in the figure above.
- This is built-in combi steam oven.

## Instructions for Use

### Introduction to Control Panel



### Pre-use instructions

When the new product is used for the first time, because the evaporation of the protective coating of heating element will produce peculiar smell, so under the condition of ensuring that the surrounding environment of the product is well ventilated, fill the water tank with water, first choose steam 100°C, 10min, after the work is over, then choose Fan GRL 220°C, 20min, all work is completed until the machine is cooled, use a damp rag to wipe and clean the inner tank, and subsequent cooking can be carried out normally.

#### Water tank filling and installation precautions:

1. In the power-on state, press "Water Tank" key, the water tank automatically popped up, take out the water tank (As shown in the picture on the right).
2. Check whether the water tank is clean before use, or whether there are foreign objects blocking the water inlet, such as odor or dirt, please promptly clean, do not clean with boiling water.
3. Open the water tank cover to add water to the tank, do not exceed the maximum water level.
4. Push the water tank after adding water into the tank slot, and there will be a chirping alert when the tank is pushed into place.

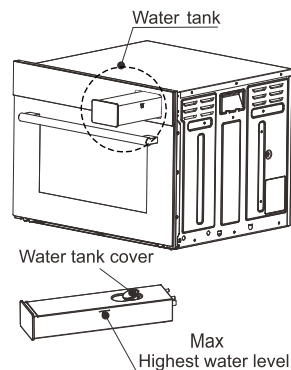

#### Note:

- It is forbidden to add hot water into the water tank to avoid deformation of the water tank and damage to the machine.

### How to Use

#### 1. Power on

Turn on the power, beep, enter standby mode, power key half lit. Long press the power key to turn on the machine and enter default mode.

### 2. Select cooking mode

Users can choose different modes to cook food according to their needs.

#### Steam mode / Bake mode / Frying mode / Gratin Bake

Steam	Steam(Normal Steam)	≡ Turbo(Turbo Steam High)	≡ Turbo(Turbo Steam Medium)
Bake	Bake	Convection	Grill
	Fan Grill	EXP(Expert Baking Mode)	
	Steam Roast(0~100% steam volume adjustable)		
Fry	Air Fry	Steam Fry	
Gratin	Gratin Bake		

Fast heat	Back	Recognition
Add Steam	Pause	Revolve

#### Take the air bake mode as an example

- ① Press "Bake" button briefly to select the air baking function and enter the setting interface of this function;
- ② Set the desired mode, temperature and time, and press "Start " to start;
- ③ Automatically enter into the preheating state, automatically enter into the working state after the preheating is completed, when the work is completed, the buzzer beeps to indicate.



#### Add Steam

- ① The humidification "☁" icon is displayed in the baking mode working state;
- ② Click on the humidification "☁" icon, start 1min to add steam, the screen displays a countdown, 1min after the end of the humidification icon once again return to the clickable state, can be operated many times;

③Water shortage alarm during humidification, pop-up water shortage prompt page (click the screen to exit), stop humidification, baking function continues.

Note:

- If there is no need to adjust the temperature and time, you can click "Start Cooking" to start directly after selecting the mode;
- Set the cooking temperature and time, the user can be based on the cooking reference table, but also according to individual taste and cooking Adjust temperature and time empirically.

### Quick warm-up function

In the grill mode preheat state, the fast preheat function is turned on by default to increase the preheat speed. To turn it off press the Quick Preheat "⏏" icon; the Quick Preheat function cannot be turned off for some grill functions.

### Rotisserie function

The rotisserie function is activated by briefly pressing the "Rotisserie" button in some modes, and then by briefly pressing the "Rotisserie" button again or the "Rotisserie" button in this mode.

The function is turned off at the end of the sub-job, and pausing in the middle does not exit the rotisserie function.

### Multi-Stage

In order to meet the user's diverse tastes, the special "Multi-Stage" mode, can be divided into 3 different modes of food cooking.

For example, the 1st stage selects "Steam", the 2nd stage selects "Bake", and the 3rd stage selects "Air Fry" operation as follows:

Setting of the 1st stage

- ① Press Multi-Segment in the main interface to enter the Multi-Segment Setting interface;
- ②Press the first paragraph "+" to enter the first paragraph of the parameter setting interface, select the parameter and press "OK" to automatically return to the parameter setting interface, repeat the operation can be set in the second paragraph, the third paragraph parameters;
- ③Press "Start" to start the work after the setting is completed.



Note:

- Set the parameters for at least two segments for multiple segments to work;
  - Under the pause state, press the return icon to enter the multi-segment setting page to modify the parameter settings, the current Work segments can only modify time parameters;
  - Gratin cannot be selected for Multi-Segment 1, and if Gratin is selected for Multi-Segment 2, Multi-Segment 3 cannot be set;
  - EXP mode cannot be selected for multi-segment work;
- On the Multi-Segment Overview page, you can press the "Delete" button, and after selecting and confirming the operation, you can delete the file.  
Remove unneeded segments.

### AI Cooking

- ①Select "AI Cooking" mode on the main page to enter the AI cooking recipe page;
- ②In this recipe page to browse and view the relevant recipes and pictures, select the recipe to be cooked click on the "start preheating" to cook, preheating is complete beeping prompt, open the door into the ingredients and click on "Start " to cook until complete.
- ③"AI cooking" function can realize the taste feedback self-learning, "AI cooking" after cooking will show tender, moderate, old, the taste of the dish for evaluation, select the taste situation, and then press the "submit evaluation" button to complete the feedback (such as this feedback selection is tender, when cooking this dish again, the machine will appropriately increase the cooking time; if this time no feedback can still be evaluated when cooking this dish next time). "button to complete the feedback (such as the feedback selection of tender, cooking this dish again, the machine will appropriately increase the cooking time; if the feedback is not this time, the next time you cook this dish can still be evaluated).



Choose your dish

Start cooking

Recipe Name	Portions	Recipe Name	Portions
Orleans Chicken Wings	2-15Pieces	Low Sugar and Low Oil Cake	6-10 inch
Pacific Saury with Salt	2-8clause	Margarita Cookies	200-500g
Chiffon Cake	6-10 inch	Sausage	2-10Pieces
Cranberry Cookies	200-500g	Chicken Chop	2-6Pieces
Portuguese Egg Tart	2-30Piece	Lotus Root Meat Pouches	2-10Pieces
Red Bean Pie	2-15Piece	Croissant	2-10Pieces
Purple Potato Pie	2-15Piece	Spicy Potato Wedges	200-600g
Egg Yolk Crisp	2-20Piece	Garlic Spareribs	500-1000g
Cookies	200-500g	Creamy toast	1-3 boxes

**Note:**

- Keep the chamber dry before using the "AI Cooking" function;
- Do not open the door during "AI Cooking" cooking to avoid cooking failure;
- When using "AI Cooking", please pay attention to the amount of ingredients, and if the ingredients you are cooking are not within the amount of ingredients. Poor cooking results may occur.

**Menu**

**Built-in 71 automatic recipes for convenience.**

- ①Select Recipes in the main interface to enter the recipe menu;
- ②In the menu interface, you can choose to categorize: Steam, Deep Fry, Bake, Bake Combination, Steam & Bake Cooking;
- ③Enter the recipe display page under the category, slide to browse the recipe, click the recipe picture to enter the recipe parameter adjustment. The entire interface allows you to set portion specifications and adjust cooking times;
- ④Parameter setting is completed, click "Start Cooking" to start the work.



Classification	Recipe Name	Recipe Name
Steam	Buns	Egg Custard
	Multi-Grains Bowl	Spareribs with Black Bean
	Rice	Egg with Tofu and Minced Meat
	Frozen Dumplings	Chicken with Scallion Oil
	Laba Porridge	Chicken with Mushroom and Black Fungus
	Crab Roe Soup Dumpling	Asparagus Beef Rolls
	Brown Sugar Cake	Perch

Classification	Recipe Name	Recipe Name
Steam	Prawn	Steam Eggplant
	Hairy Crab	Baby Cabbage with Sauce
	Chopped Pepper Fish Head	Blueberry Yams
	Tremella and Lotus Seed Soup	Honey Broccoli
	Tangerine Peel and Red Bean Paste	Black Bean Sauce with Seasonal vegetables
	Yoghurt	Chopped Pepper Enoki Mushrooms
Bake	Sweet Potato	Pineapple Chicken Skewers
	Pizza	Chicken with Fruits
	Taro Paste Soft Baguette	Honey-Glazed Char Siu
	Garlic Potatoes	Leg of Lamb
	French Lamb Chops	Teriyaki Salmon
	Potato Chips Chicken Wings	Cupcakes
	Steak	Cream Cake
	Yakitori	Cream Puffs
Fry	Chips	Chicken Leg
	Cakoi	Cheese Hot Dog Stick
	Popcorn Chicken	King Oyster Mushroom
	Plain Chicken Nuggets	Roasted Gluten
	Spicy Crispy Sausage	
Gratin	Cheese Sweet Potatoes	Garlic Prawns
	Pineapple Baked Rice	Garlic Oysters
	Potato with Bacon	Cheese Baked Corn
	Bolognese Pasta	
Combi	Hand-Baked Buns	Braised Chicken
	Crispy Aromatic Duck	Cheese Lobste
	Grilled Tendon	Spicy Grilled Fish
Steam-Bake	Rack of Lamb + Babe Pumpkin	
	Grilled Shrimp + Baby Cabbage with Sauce	
	Orleans Grilled Wings + Rice	
	Sausage + Fish	
	Cake + Snow Pear Soup	
	Garlic Oysters + Chopped Pepper Enoki	
	French Lamb Chops + Taro	

**Note:**

- Some recipes require the food to be removed and processed halfway through the meal, and the machine will beep to remind you;

- While in operation, you can pause to adjust the cooking time;
- The recipe page allows you to select Daily/Nutrition.

**Auxiliary Mode**

Auxiliary functions include: professional fermentation, thawing, heat preservation, cleaning, drying, sterilization, descaling

Select auxiliary in the main interface to enter the auxiliary menu selection interface, where you can select seven auxiliary mode.The parameters are set, and slide to select the parameters, the parameters are set and click on "start working" to start.

**Note:**

- The steam function will remind the user to descale after it has worked for a certain cumulative period of time, please descale;
- To ensure the descaling effect during the descaling process, please do not turn off the machine in the middle of the process. In case of power failure or other abnormal situations, please turn on the descaling function again after recovery;
- Cleaning, drying, and sterilizing modes are not adjustable for temperature and time;
- Professional Fermentation contains eight categories, including customizable adjustable fermentation temperature and time; the other seven categories are Steamed Buns/Buns, Rice Cake/Fat Cake, Sweet Breads, Shortening Breads, Oyster Buns, Yogurt, and Mash, which provide suggested temperatures and times for users' convenience;
- It is recommended to open the door to dry better when using the dry mode.

**System settings**

Click Settings in the main interface to enter the System Settings interface.

**Language Settings**

In the general interface of settings, click "Language Settings" to enter the language settings page; then select the language on this page.

**About the product**

Under the General Settings screen, click "About Product" to display product information.

Note:Press and hold the product model for a few seconds in this screen to enter ECO mode.

**Completion of work**

Under the general interface of settings, click "Restore Factory", and follow the on-screen text guide to choose to restore factory settings.

**Completion of work**

1. When the work is finished, the buzzer beeps to indicate.
2. In standby mode, it will turn off automatically after a few minutes without any operation.
3. During the working process, long press the "⏻" key can directly stop heating, into the shutdown state.

**Note:**

- If the internal temperature of the product is too high, the cooling fan will be working for a period of time and then stop running, which is conducive to prolonging the life of the machine;
- To shorten the heat dissipation time, it is recommended to leave the product door open when dissipating heat.

**Mode Menu**

Mode	Default working temperature ( °C )	Default working time (min)	Temperature range ( °C )	Time range (min)
Steam (Normal Steam)	100	20	30-150	1-120
Turbo(Turbo Steam )	/	10	/	1-120
Bake	160	30	35-230	1-120
Convection	200	30	35-250	1-120
Grill	200	30	35-230	1-120
Fan Grill	160	30	35-250	1-120
EXP(Expert Baking Mode)	Upper temperature:180 Lower temperature:160	30	100-200	1-120
Steam Roast	200	30	35-230	1-120
Air Fry	200	30	35-230	1-120
Steam Fry	200	30	150-230	1-120
Gratin (Gratin Bake)	280	8	-	1-30
Professional Fermentation (Customizable)	35	40	30-45	1-720
Defrost	/	25	/	1-60
Keep Warm	60	2h	50-80	1-12h
Clean	/	10	/	/
Drying	/	10	/	/
Sterilize	/	30	/	/
Descale	/	/	/	/

**Cooking Reference List**

Mode	Level	Food	Baking Layer Position	Apparatus Used	Temperature (°C)	Baking Time (min)	Notes
Steam	/	Whole Chicken	3	Steam plate(with hole)/Fryer grill	100	45	Approximately1200g
	/	Beef Tendon	3	Steam plate(with hole)/Fryer grill	120	100	Approximately500g, chopped into pieces
	/	Beef Brisket	3	Steam plate(with hole)/Fryer grill	150	80	Approximately500g, cut into chunks
	/	Duck Meat	3	Steam plate(with hole)/Fryer grill	150	30	Approximately 1000g, chopped into pieces
	/	Chicken Chunks	3	Steam plate(with hole)/Fryer grill	100	25	Approximately500g, chopped into pieces
	/	Spare Ribs	3	Steam plate(with hole)/Fryer grill	100	30	Approximately500g, chopped into pieces
	/	Meat Patty	3	Steam plate(with hole)/Fryer grill	100	15	Approximately350g, minced meat
	/	Diced Meat	3	Steam plate(with hole)/Fryer grill	100	30	Approximately500g, cut into chunks
	/	Chinese Sausage	3	Steam plate(with hole)/Fryer grill	100	15	Approximately200g, sliced
	/	Steamed Egg Custard	3	Steam plate(with hole)/Fryer grill	95	20	2 eggs, egg-to-water ratio 1:2
	/	Sweet Potato	3	Steam plate(with hole)/Fryer grill	100	40	Approximately 1000g, 9 pieces total
	/	Corn	3	Steam plate(with hole)/Fryer grill	100	20	Approximately 1000g, 3 pieces total
	/	Enoki Mushrooms	3	Steam plate(with hole)/Fryer grill	100	12	Approximately400g
	/	Cooked Rice	3	Steam plate(with hole)/Fryer grill	100	30	300g rice, rice-to-water ratio 1:1.2, divided into 3 bowls
	/	Handmade Steamed Buns	3	Steam plate(with hole)/Fryer grill	100	28	Approximately80g per piece, 8 pieces total
	/	Frozen Dumplings	3	Steam plate(with hole)/Fryer grill	100	12	1 whole plate, approximately30 pieces
	/	Steamed Sponge Cake	3	Steam plate(with hole)/Fryer grill	100	40	8-inch cake pan
	/	White Fungus Soup	3	Steam plate(with hole)/Fryer grill	110	100	Approximately15g dried white fungus, approximately1000g clean water
	/	Chinese Mitten Crab	3	Steam plate(with hole)/Fryer grill	100	25	1200g Chinese mitten crabs, approximately8 crabs
	/	Fish Head	3	Steam plate(with hole)/Fryer grill	120	11	Fish head, approximately700g, split into two halves

Mode	Level	Food	Baking Layer Position	Apparatus Used	Temperature (°C)	Baking Time (min)	Notes
Turbo Steam	medium steam	Prawns	3	Steam plate(with hole)/Fryer grill	/	4	Approximately400g
	Medium steam	Sea Bass	3	Steam plate(with hole)/Fryer grill	/	9	Approximately400g fish, scored on the back (incisions made on the fish back for better flavor absorption)
	High steam	Broccoli	3	Steam plate(with hole)/Fryer grill	/	3	Approximately200g
	High steam	Long Eggplant	3	Steam plate(with hole)/Fryer grill	/	13	Approximately400g, cut into sections
	High steam	Baby Napa Cabbage	3	Steam plate(with hole)/Fryer grill	/	13	Approximately300g
Fan Grill	/	Whole Chicken	3	Toasting fork assembly+Baking tray	150-160	50-60	Whole chicken, approximately1200g
	/	Whole Duck	3	Toasting fork assembly+Baking tray	150-160	70-80	Whole duck, approximately2000g
	/	Grilled Skewers	3	Fryer grill+Baking tray	220-230	5-15	8 skewers of meat
Bake	/	Chicken Wings	3	Fryer grill+Baking tray	180-190	20-30	Approximately700g, 15 pieces total
	/	Dinner Rolls	3	Baking tray	150-160	20-30	1 whole plate
	/	Toast	3	Fryer grill	180-200	40-50	450g toast box
Convection	/	Whole Plate of Cake	3	Baking tray	150-160	25-35	1 whole plate
	/	Cookies	3	Baking tray	160-170	15-25	1 whole plate
	/	Mooncakes	3	Baking tray	180-200	20-30	12 mooncakes
	/	Pizza	3	Baking tray	200-210	15-20	Frozen pizza base, 8-inch
	/	Cake	3	Fryer grill	140-160	50-60	8-inch cake pan
	/	Egg Tarts	3	Baking tray	200-210	15-25	15 egg tarts
	/	Cheese Toast	3	Fryer grill	190-200	5-10	4 slices of toast
Grill	/	Grilled Prawns	3	Baking tray	200-210	8-15	Prawns, approximately500g
	/	Oysters	3	Baking tray	210-220	10-15	Oysters, approximately1000g, 12 oysters total
Roast with Steam	90%	Salmon	3	Baking tray	210-220	10-15	Approximately200g
	100%	Sweet Potato	3	Baking tray	220-230	45-60	Approximately 1000g, 9 pieces total
	100%	Potato	3	Baking tray	180-190	20-30	Approximately500g, cut into chunks
Multi-Stage	/	Crispy Duck	3	Fryer grill+Baking tray	Nutritional steaming at 105°C for 70 minutes + Fan baking at 210°C for 30 minutes	90-110	Whole duck, approximately2000g
	/	Crispy Pork Knuckle	3	Fryer grill+Baking tray	Nutritional steaming at 110°C for 80 minutes + Fan baking at 220°C for 25 minutes	100-110	Pork elbow, approximately1500g
Air Fry	/	French Fries	3	Fryer grill+Baking tray	200-220	15-25	Frozen French fries, approximately200g
	/	Frozen Youtiao (	3	Fryer grill+Baking tray	190-200	5-10	Approximately240g, 3 sticks total

Mode	Level	Food	Baking Layer Position	Apparatus Used	Temperature (°C)	Baking Time (min)	Notes
Air Fry	/	Chicken Cutlet	3	Fryer grill+Baking tray	220-230	15-25	Semi-finished chicken cutlets, approximately350g
	/	Lava Stone Grilled Sausages	3	Fryer grill+Baking tray	200-210	15-25	Approximately400g, 8 sticks total
Steam Fry	/	Lotus Root Patties	3	Fryer grill+Baking tray	200-220	10-20	Semi-finished lotus root cakes, approximately360g, 12 pieces total
	/	Pork Belly	3	Fryer grill+Baking tray	190-200	20-30	Approximately500g, 5 sections total
	/	Crispy Fried Pork Strips	3	Fryer grill+Baking tray	210-220	10-20	Semi-finished crispy pork strips, approximately250g
	/	Original Flavor Chicken Chunks	3	Fryer grill+Baking tray	200-220	15-25	Semi-finished original chicken nuggets, approximately300g
	/	Popcorn Chicken	3	Fryer grill+Baking tray	220-230	15-25	Frozen popcorn chicken, approximately300g
Gratin Bake	/	Baked Oysters	3	Fryer grill	280	10-15	Approximately 1000g, 12 pieces total
	/	Baked Prawns	3	Fryer grill	280	8-15	Approximately300g, 14 pieces total
	/	Baked Scallops with Vermicelli	3	Fryer grill	280	8-15	Approximately200g, 6 pieces total

Note:

- The food cooking temperatures and times in the above table are for reference only, and during the food cooking process, the user can adjust the temperature, time and mode according to your personal taste and cooking experience.
- In Grill Mode, before grilling, marinate the food that needs marinating with the prepared seasonings for about 30-40 minutes. This will make the food more flavorful.
- In Grill Mode, to ensure even heat distribution during grilling, it is recommended to flip the food.
- The modes that require the water tank to be filled to the maximum level include: Steaming Modes (Nutritious Steaming, Powerful Steaming), Grill Modes (Humidified Grilling), Frying Modes (Steam Frying), and Auxiliary Functions (Professional Fermentation, Defrost, Keep Warm, Clean, Sterilize, Descale).

Common Phenomenon and Treatment when Baking

Function	Symptom	Cause analysis	Disposition
Steam	Undercooked food from steaming	① The steaming time is too short ② The portion of steamed food is too large or too big ③ The door is opened too many times during steaming ④ Incorrect choice of attachment	① Extend the steaming time ② Steam with the appropriate portion size ③ Do not open the door as much as possible during the steaming process ④ Select the correct attachment for steaming
	Steamed food is too old or overcooked	① The steaming time is too long ② The steaming temperature is too high ③ Incorrect mode selection	① Reduce steaming time ② Turn down the temperature ③ Choose the right model
	Steamed food is soupy	① Failure to control water before steaming ② Liquid seasonings (cooking wine, soy sauce, etc.) there's too much volume	① Drain on kitchen paper before steaming ② Reduce the amount of liquid seasoning
Bake	Uneven baking	① Incorrect choice of mode ② Food is not of the same size or food is not placed evenly ③ Incorrect location of cooking layer	① Choose the right model ② Cut food evenly in size and evenly on the attachment place ③ Select the appropriate cooking layer position
	Grilled food top coat color or bottom color deeper	① Incorrect choice of mode ② The baking temperature is too high ③ The cooking layer is positioned too high	① Choose the right model ② Turn down the temperature ③ Repositioning to a lower level
	Grilled food light color or not sear through	① Incorrect choice of mode ② The baking temperature is too low ③ The baking time is too short ④ Incorrect location of the cooking layer ⑤ High number of box door openings	① Choose the right model ② Turn up the temperature ③ Extended baking time ④ Choose the right location for the cooking layer ⑤ When cooking food, try not to open the door of the box.
	Baked cake cracked and deep thick layer of potpourri	① The baking time is too long ② The baking temperature is too high ③ Errors in the recipe or process of making cakes and pastries ④ Incorrect cooking layer position or mode selection ⑤ Incorrect mold selection	① Reduce baking time ② Turn down the temperature ③ Adjust the formula and choose the correct operation process ④ Select the appropriate cooking layer position or the right mode ⑤ Replacement of suitable molds
	Uneven or uncrispy	① Food not turned over during cooking ② Setting temperature too low or time too short ③ Incorrect choice of attachments ④ Foods are more suitable for cooking in a deep fryer	① Turning or flipping food during cooking ② Turn up the temperature or extend the time ③ Selection of the correct attachment ④ Brush a layer of oil on the surface of the food

Common Faults and Solutions

The following table lists the general faults, please confirm and deal with them according to the listed instructions. If you still cannot deal with them or cannot confirm the cause of the faults, please contact your local dealer or service center. For your safety, we would like to remind you that you should not disassemble and repair the product by yourself.

Failure phenomenon	Reason	Processing method
Can not work	Power cut off, or power plug was not plugged in	Make sure the power is on, or try to plug in again
The display is not bright	Power failure or computer board failure	Check the power supply or contact professional repairer
The lights are not on	Power failure or bulb failure	Check the power supply or contact professional repairer
There is leakage of air and water at work	The door is not tightly closed, the door seal is not in place or the door seal is damaged	Check the door closure, reinstall the door seal or contact professional repairer
Monitor "Water Shortage" flashes	The water tank is short of water or the water level detection switch and water pump fail	Add water or contact professional repairer
	Not identified to the water tank, the water tank is not installed or not installed in place	Correctly install the water tank, if the installation is still flickering Please contact professional repairer
Water tank can not be popped	Pusher motor failure, computer board failure	Please contact professional repairer
The display shows the prompt "Water Tank Not In Place"	The water tank is not installed or not installed in place	Install the water tank correctly. If the prompt still appears after proper installation, please contact professional maintenance personnel
The display shows "E3: Heating System Fault"	The heating tube is not working	Please contact professional repairer
The display shows "E5-1: Upper Chamber Temp Sensor Failure"	The temperature sensor on the cavity is abnormal.	Please contact professional repairer

Failure phenomenon	Reason	Processing method
The display shows "E5-2: Lower Chamber Temp Sensor Failure"	The temperature sensor under the cavity is abnormal	Please contact professional repairer
The display shows "E5-3: Cooling Fan Temp Sensor Failure"	Fault of the temperature sensor for the cooling fan	Please contact professional repairer
The display shows "E5-9: Oxygen Sensor Failure"	The oxygen sensor is not working	Please contact professional repairer
The display shows "E6: Communication Failure"	Abnormal communication between the key panel and the power board	Please contact professional repairer
The display shows "E7: Cooling Fan Failure"	The cooling fan is not working	Please contact professional repairer

## Maintenance and Care

Important: Before cleaning the machine, you must first power off.

Must always keep the appliance clean to ensure that there is no accumulation of fat and grease around the heating element, fan; fryer grill and baking tray, etc. must be cleaned to avoid the accumulation of fat to trigger a fire; meat can be wrapped in aluminum foil while baking for cleaning; any fat and grease will form a lacquer-like layer inside the appliance and be difficult to clean, so it should be cleaned after each use.

1. Inner Cavity: Clean with warm water. Do not use corrosive or abrasive cleaners. For stubborn stains, use a nylon brush or neutral cleaner; never scrub with a steel wool pad, as this may cause irreparable damage to the surface. Ensure all cleaner residues inside the cavity are completely rinsed off. After cleaning, dry the cavity with a cloth to keep it dry, or use the drying mode to dry it.

2. Glass Panel: Clean the glass surfaces on the door and control panel immediately when they get dirty. For tough dirt, use a neutral cleaner; do not scrub with a steel wool pad to avoid scratching the surface. Wipe the glass dry with a cloth after cleaning.

3. It is recommended to remove the water tank and empty the water after each use to prevent odor from developing over time.

4. After use, you must promptly clean up any accumulated water in the water collection tray to prevent overflow.

5. Removing and Installing the Fan Cover: The fan cover is fixed inside the cavity with 4 nuts. To remove it, simply unscrew the nuts counterclockwise.

Note: The fan cover must be reinstalled after cleaning.

6. Door Gasket Installation Method: With both hands, pinch the left and right A and B semicircular corners on the upper edge of the door gasket. Align them with the semicircular grooves on the upper edge of the front panel and press firmly into place. Then, take the left and right C and D semicircular corners on the lower edge of the door gasket, align them with the semicircular grooves on the lower edge of the front panel, and press firmly into place. Finally, press all four edges fully into their respective grooves. After pressing, ensure the door gasket is flat, wrinkle-free, and has no gaps.



Water Tank

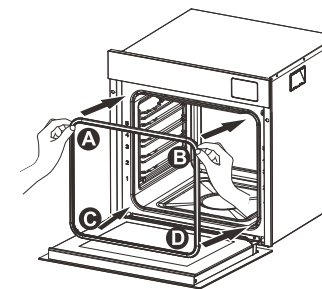

Installation Diagram of the Door Gasket

7. When adding water to or cleaning the water tank, you can open the tank cover to perform the operation.

8. Removing and Installing the Shelves (The method for left and right shelves is the same): Press the position of the shelf (Figure 1) until the shelf is detached from the positioning screws. Then take it out upward following the arrow in Figure 2 to complete the removal. To reinstall the shelf, align the lower end of the shelf with screws 1 and 2 as shown in Figure 2 and insert it, then fasten the upper end of the shelf into the positioning screws.

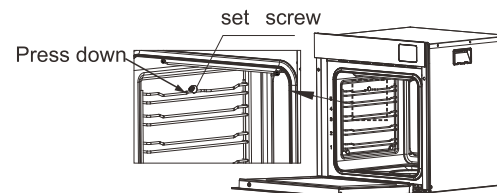

Figure1

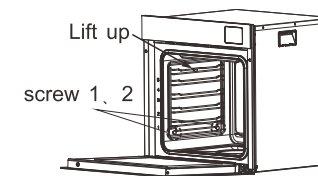
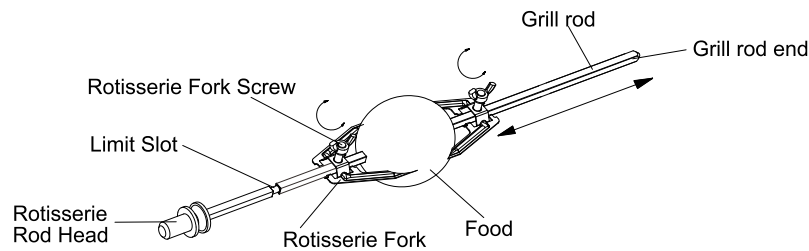

Figure2

9. Usage Method of the Rotisserie Assembly

Securing the Food:

- ① Loosen the rotisserie fork screws, slide one side of the rotisserie fork and its screw along the rotisserie rod to the end, then remove them.
- ② Insert the food onto the rotisserie rod, then reinstall the removed rotisserie fork back onto the rod.
- ③ Adjust the food to the appropriate position between the end of the grill rod and the limit slot, move the two sides of the grill fork so that the tips of both sides are inserted into the food for limiting, and tighten the grill fork screws to complete the food fixation.



Installation of the Rotisserie Assembly:

- ① Place the rotisserie bracket on the middle layer of the shelf, then insert the rotisserie assembly with the secured food obliquely from above the rotisserie bracket into the rotisserie rod mounting hole on the rear side of the cooking cavity. Twist it slightly left and right to ensure the edges fit properly.
- ② Adjust the position of the rotisserie bracket, and place the groove at the other end of the rotisserie rod into the groove of the rotisserie bracket.

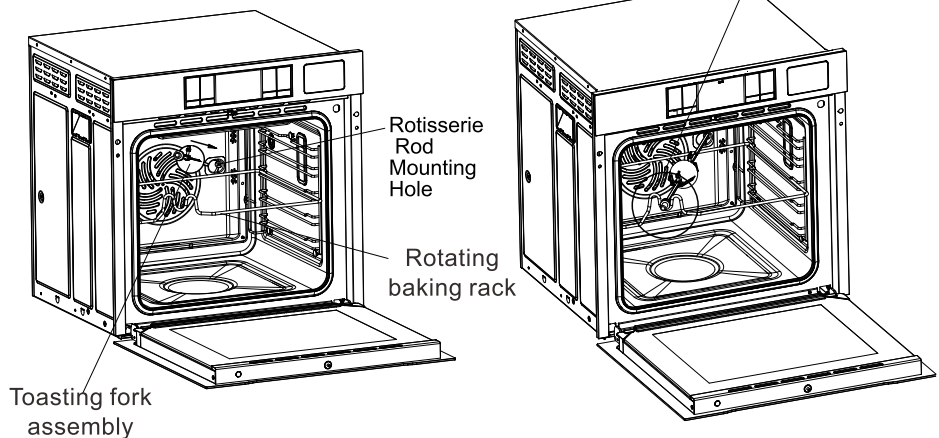
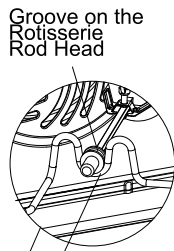

Note:

- When using the rotisserie function, ensure the rotisserie assembly is properly installed before activating this function.
- When the rotisserie function is completed, first remove one end of the rotisserie rod from the groove of the rotisserie bracket, then move the bushing end of the rotisserie rod away from the rotating shaft, and finally take out the rotisserie bracket.
- Accessories such as the rotisserie assembly inside the cooking cavity will be extremely hot. Do not touch them directly with your hands to avoid scalding.

Electrical Schematic Diagram

